

High Speed Drill(2D)

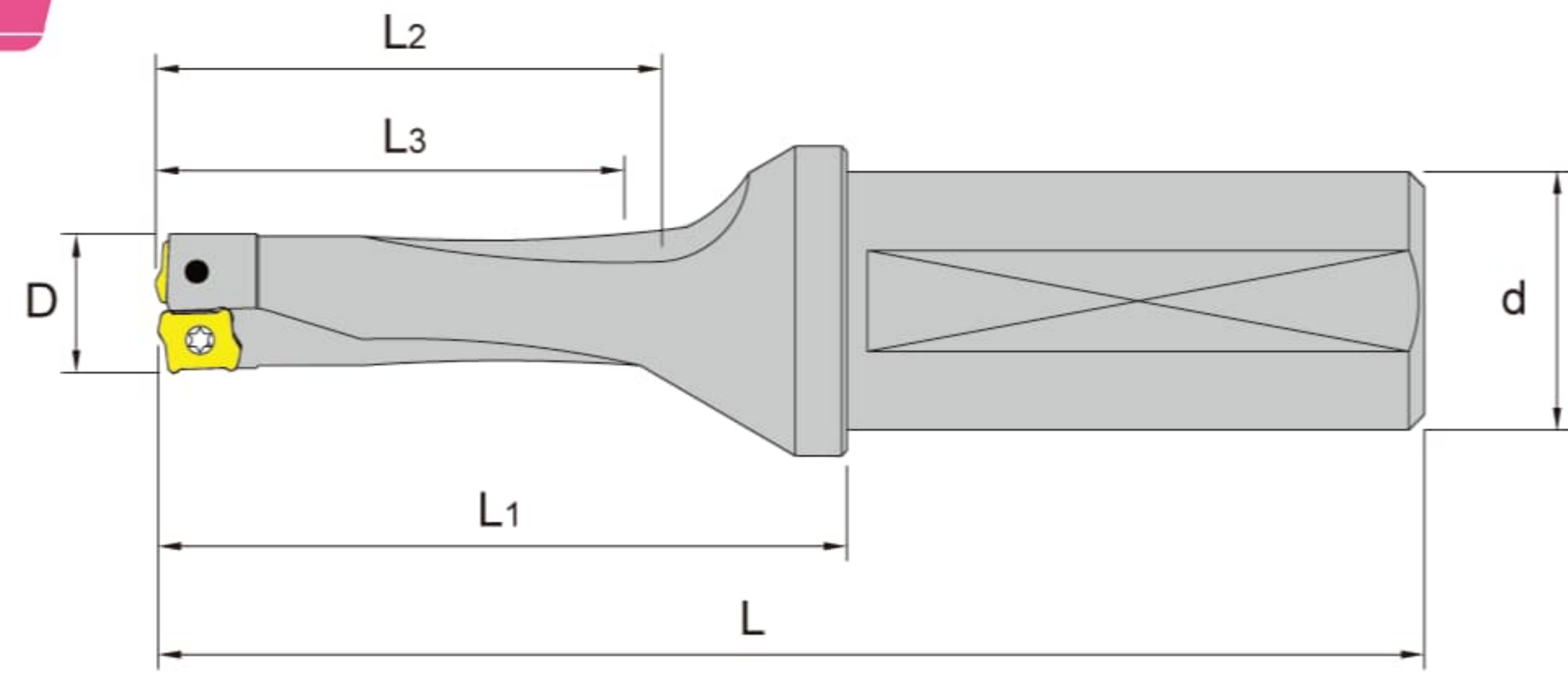
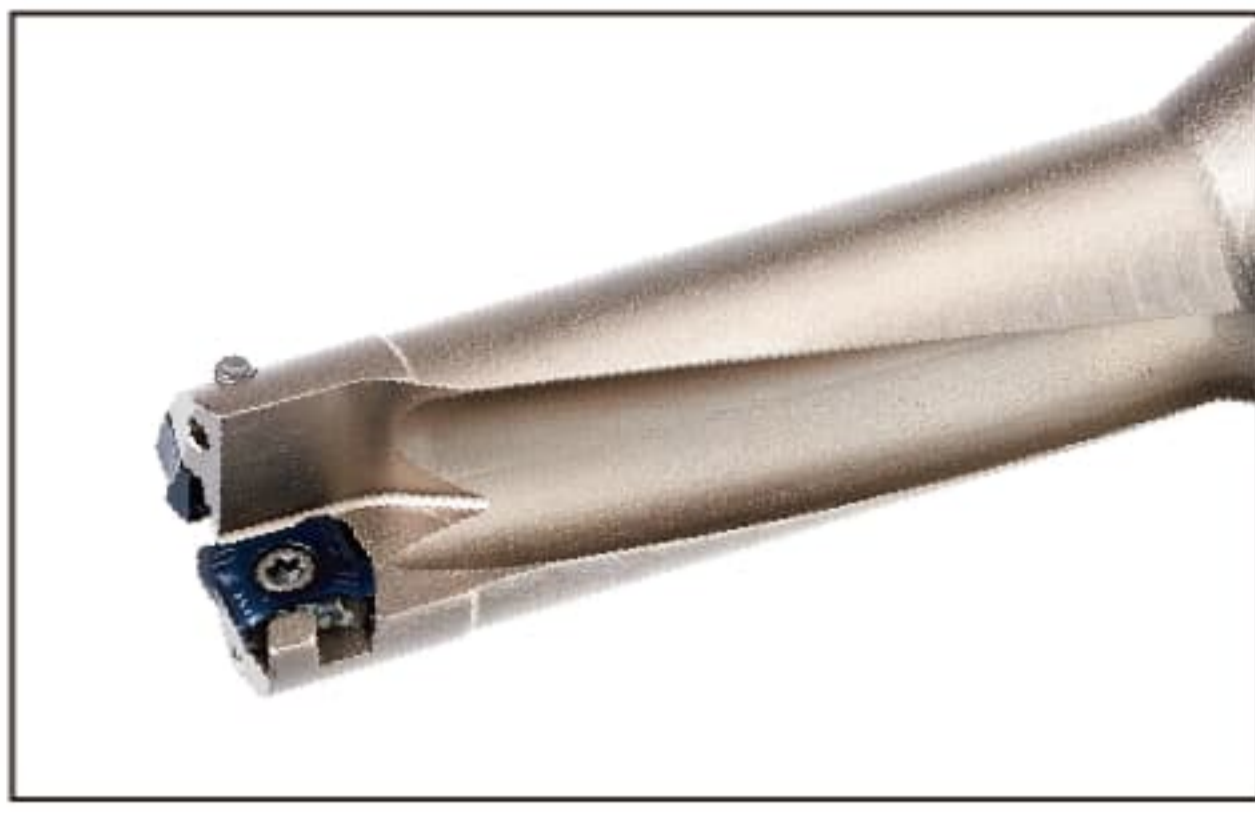

■ For Sumitomo/Nachi Insert

Order number	Insert number	Dimensions (mm)						Screw	Wrench
		D	L	L1	L2	L3	d		
C25 LP14-28	LPMX 06T206	14	97	53	33	28	25	BFTX 02506	TRX08
LP15-30		15	99	55	35	30			
LP16-32		LPMX 07T208	16	101	57	37			
LP17-34	17		103	59	39	34			
LP18-36	LPMX 080308		18	117	61	41			
LP19-38		19	119	63	43	38			
LP20-40		20	121	65	45	40			
C32 LP21-42		LPMX 090308	21	123	67	47	42	32	BFTX 02510
LP22-44	22		125	69	49	44			
LP23-46	23		127	71	51	46			
XP24-48	XPMX 11T308	24	129	73	53	48			
XP25-50		25	131	75	55	50			
XP26-52		26	133	77	57	52			
XP27-54		27	135	79	59	54			
XP28-56	XPMX 13T308	28	137	81	61	56			
XP29-58		29	139	83	63	58			
XP30-60		30	141	85	65	60			
XP31-62		31	143	87	67	62			
XP32-64		32	145	89	69	64			
XP33-66	XPMX 150408	33	147	91	71	66			
XP34-68		34	149	93	73	68			
XP35-70		35	151	95	75	70			
XP36-72		36	153	97	77	72			
XP37-74		37	155	99	79	74			
XP38-76	XPMX 170412	38	157	101	81	76			
XP39-78		39	159	103	83	78			
XP40-80		40	161	105	85	80			
C40 XP41-82		41	172	107	87	82	40	BFTX 0410	TRX15
XP42-82	42	174	109	89	84				
XP43-82	43	176	111	91	86				
XP44-82	XPMX 200412	44	178	113	93	88			
XP45-82		45	180	115	95	90			
XP46-82		46	182	117	97	92			
XP47-82		47	184	119	99	94			
XP48-82		48	186	121	101	96			
XP49-82		49	188	123	103	98			
XP50-82	50	190	125	105	100				

G

High Speed Drill(3D)

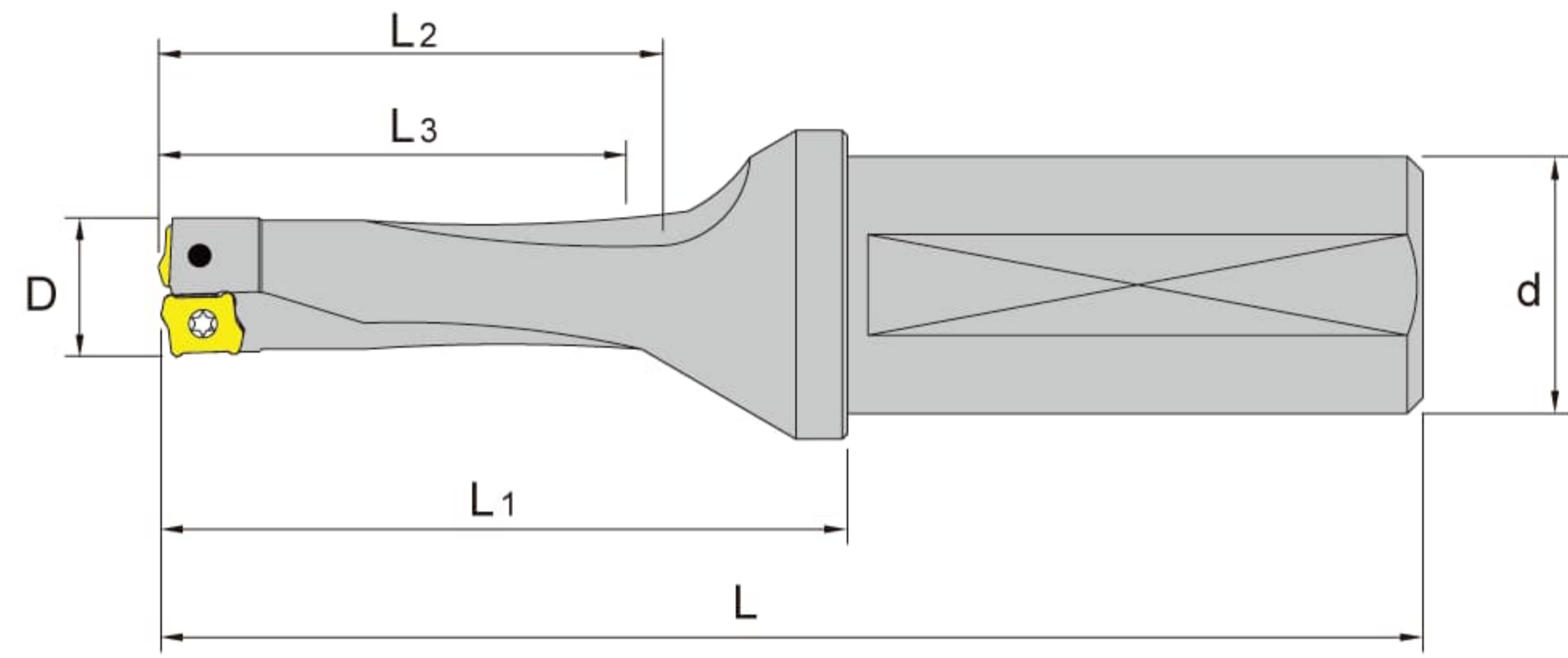
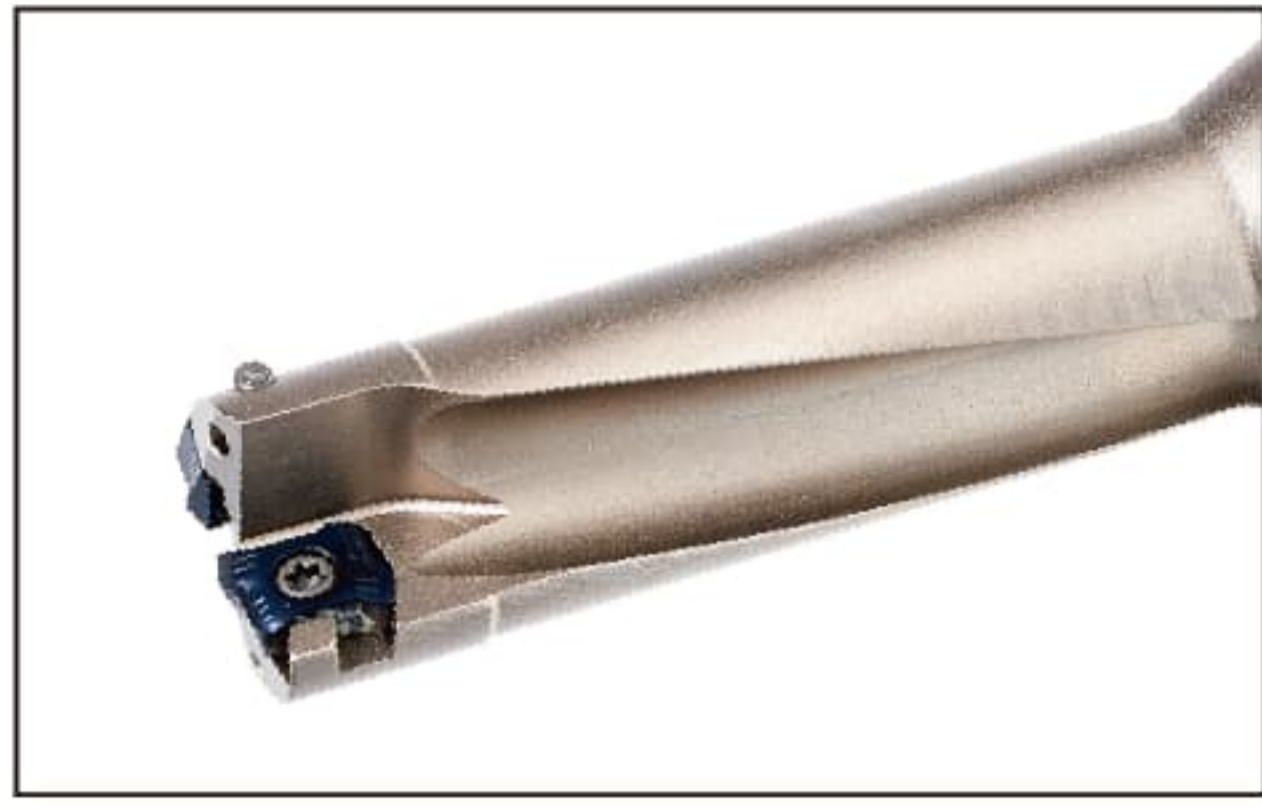

■ For Sumitomo/ Seco Insert

Order number	Insert number	Dimensions (mm)						Screw	Wrench	
		D	L	L1	L2	L3	d			
C25 LP14-42	LPMX 06T206	14	111	67	47	42	25	BFTX 02506	TRX08	
LP15-45		15	114	70	50	45				
LP16-48	LPMX 07T208	16	117	73	53	48				
LP17-51		17	120	76	56	51				
LP18-54	LPMX 080308	18	135	79	59	54				
LP19-57		19	138	82	62	57				
LP20-60		20	141	85	65	60				
C32 XP21-63	LPMX 090308	21	144	88	68	63	32	BFTX 02510	TRX08	
XP22-66		22	147	91	71	66				
XP23-69		23	150	94	74	69				
XP24-72	XPMX 11T308	24	153	97	77	72				
XP25-75		25	156	100	80	75				
XP26-78		26	159	103	83	78				
XP27-81		27	162	106	86	81				
XP28-84	XPMX 13T308	28	165	109	89	84				
XP29-87		29	168	112	92	87				
XP30-90		30	171	115	95	90				
XP31-93		31	174	118	98	93				
XP32-96		32	177	121	101	96				
XP33-99	XPMX 150408	33	180	124	104	99				
XP34-102		34	183	127	107	102				
XP35-105		35	186	130	110	105				
XP36-108		36	189	133	113	108				
XP37-111		37	192	136	116	111				
XP38-114	XPMX 170412	38	195	139	119	114	40	BFTX 0410	TRX15	
XP39-117		39	198	142	122	117				
XP40-120		40	201	145	125	120				
C40 XP41-123		41	213	148	128	123				
XP42-126		42	216	151	131	126				
XP43-129		43	219	154	134	129				
XP44-132		XPMX 200412	44	222	157	137				132
XP45-135			45	225	160	140				135
XP46-138	46		228	163	143	138				
XP47-141	47		231	166	146	141				
XP48-144	48		234	169	149	144				
XP49-147	49		237	172	152	147				
XP50-150	50		240	175	155	150				

High Speed Drill(2D)

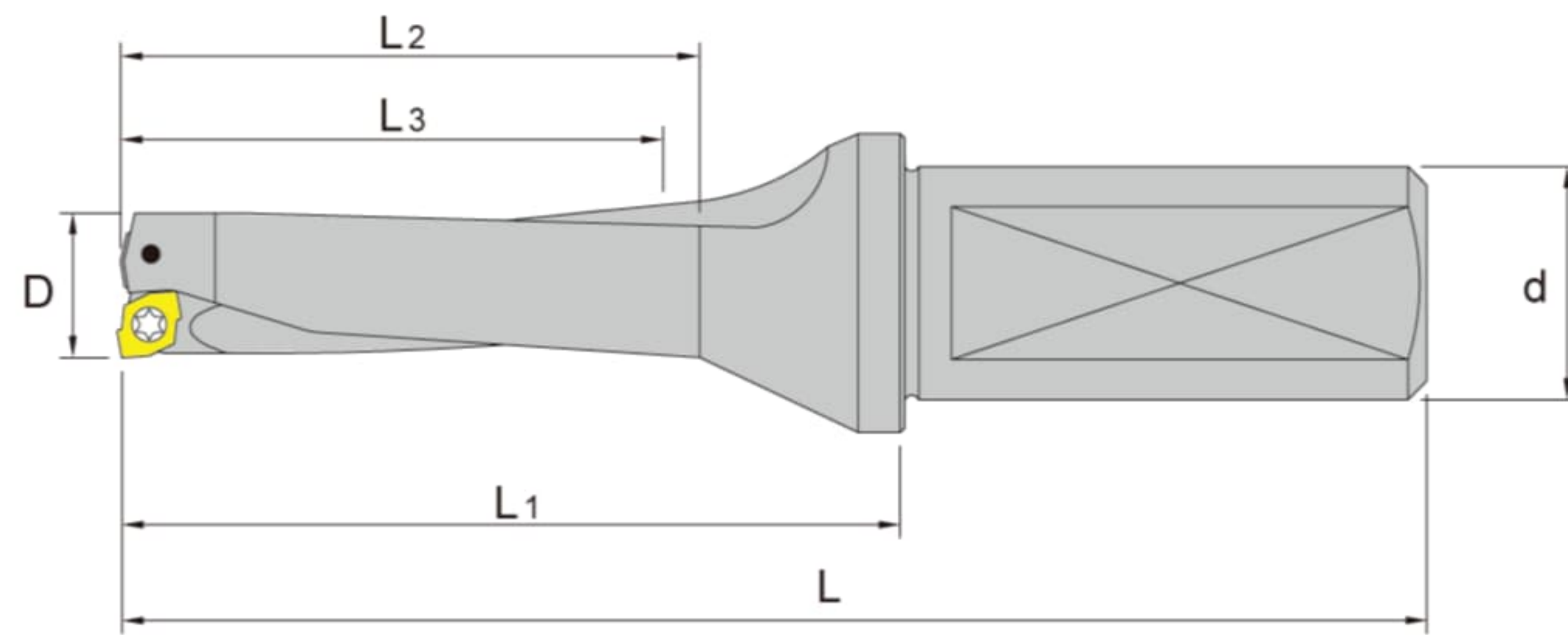

■ For Kyocera Insert

Order number	Insert number	Dimensions (mm)						Screw	Wrench		
		D	L	L1	L2	L3	d				
C20 ZC13-26	ZCMT050203	13	95	51	31	26	20	BFTX 0206	TRX06		
	ZC14-28	ZCMT050203SP	14	97	53	33				28	
	ZC15-30	ZCMT050203SU	15	99	55	35				30	
C25 ZC16-32	ZCMT06T204	16	101	57	37	32	25	BFTX 02206	TRX07		
		ZC17-34	17	103	59	39				34	
		ZC18-36	ZCMT06T204SP	18	117	61				41	36
C32 ZC19-38	ZCMT06T204SU	ZC20-40	19	119	63	43	38	32	BFTX 02506	TRX08	
		ZC21-42	20	121	65	45	40				
		ZC22-44	21	123	67	47	42				
C40 ZC23-46	ZCMT080304	ZC24-48	22	125	69	49	44	40	BFTX 0410	TRX15	
		ZC25-50	23	127	71	51	46				
		ZC26-52	ZCMT080304SP	24	129	73	53				48
C40 ZC27-54	ZCMT080304SU	ZC28-56	25	131	75	55	50	40	BFTX 05085	TRX20	
		ZC29-58	26	133	77	57	52				
		ZC30-60	27	135	79	59	54				
C40 ZC31-62	ZCMT10T304	ZC32-64	28	137	81	61	56	40	BFTX 06012	TRX25	
		ZC33-66	ZCMT10T304SP	29	139	83	63				58
		ZC34-68	30	141	85	65	60				
C40 ZC35-70	ZCMT12T306	ZC36-72	31	143	87	67	62	40	BFTX 06012	TRX25	
		ZC37-74	32	145	89	69	64				
		ZC38-76	ZCMT12T306SP	33	147	91	71				66
C40 ZC39-78	ZCMT12T306SP	ZC40-80	34	149	93	73	68	40	BFTX 06012	TRX25	
		ZC41-82	35	151	95	75	70				
		ZC42-84	36	153	97	77	72				
C40 ZC43-86	ZCMT150408	ZC44-88	37	155	99	79	74	40	BFTX 06012	TRX25	
		ZC45-90	38	157	101	81	76				
		ZC46-92	ZCMT150406SP	39	159	103	83				78
C40 ZC47-94	ZCMT150408	ZC48-96	40	161	105	85	80	40	BFTX 06012	TRX25	
		ZC49-98	41	172	107	87	82				
		ZC50-100	42	174	109	89	84				
C40 ZC51-102	ZCMT150408	ZC52-104	43	176	111	91	86	40	BFTX 06012	TRX25	
		ZC53-106	44	178	113	93	88				
		ZC54-108	45	180	115	95	90				
C40 ZC55-110	ZCMT150408	ZC56-112	46	182	117	97	92	40	BFTX 06012	TRX25	
		ZC57-114	47	184	119	99	94				
		ZC58-116	48	186	121	101	96				
C40 ZC59-118	ZCMT200608	ZC59-118	49	188	123	103	98	40	BFTX 06012	TRX25	
		ZC59-118	50	190	125	105	100				
		ZC59-118	51	192	127	107	102				
C40 ZC59-118	ZCMT200608	ZC59-118	52	194	129	109	104	40	BFTX 06012	TRX25	
		ZC59-118	53	196	131	111	106				
		ZC59-118	54	198	133	113	108				
C40 ZC59-118	ZCMT200608	ZC59-118	55	200	135	115	110	40	BFTX 06012	TRX25	
		ZC59-118	56	202	137	117	112				
		ZC59-118	57	204	139	119	114				
C40 ZC59-118	ZCMT200608	ZC59-118	58	206	141	121	116	40	BFTX 06012	TRX25	
		ZC59-118	59	208	143	123	118				
		ZC59-118	59	208	143	123	118				

G

High Speed Drill(3D)

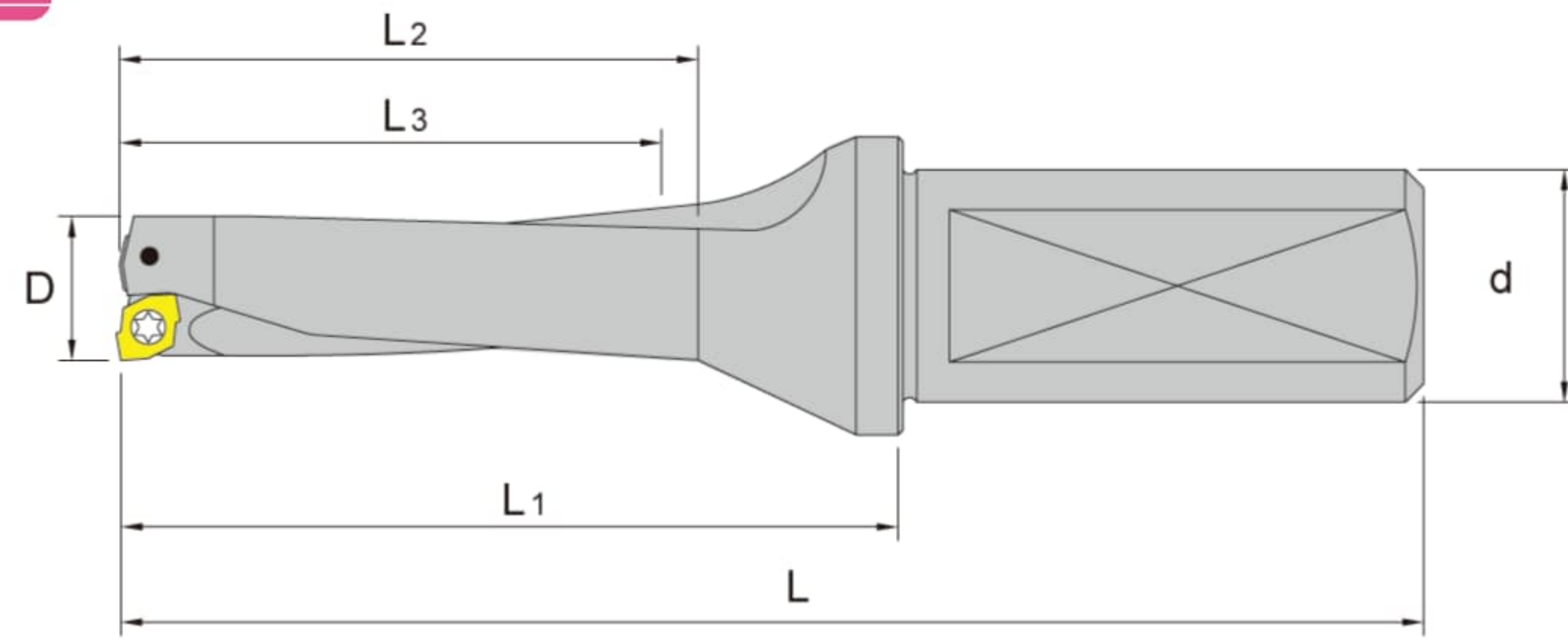

■ For Kyocera Insert

Order number	Insert number	Dimensions (mm)						Screw	Wrench	
		D	L	L1	L2	L3	d			
C20 ZC13-39	ZCMT050203	13	108	63	44	39	20	BFTX 0206	TRX06	
	ZCMT050203SP	14	111	67	47	42				
	ZCMT050203SU	15	114	70	50	45				
	ZC16-48	16	117	73	53	48				
	ZC17-51	17	120	76	56	51				
C25 ZC18-54	ZCMT06T204	18	135	79	59	54	25	BFTX 2206	TRX07	
	ZCMT06T204SP	19	138	82	62	57				
	ZCMT06T204SU	20	141	85	65	60				
	ZC21-63	21	144	88	68	63				
ZC22-66	ZCMT080304	22	147	91	71	66	32	BFTX 02506	TRX08	
		ZCMT080304SP	23	150	94	74				69
		ZCMT080304SU	24	153	97	77				72
C32 ZC25-75	ZCMT10T304	25	156	100	80	75	32	BFTX 0410	TRX15	
		ZCMT10T304SP	26	159	103	83				78
ZC27-81	ZCMT12T306	27	162	106	86	81	32	BFTX 05085	TRX20	
ZC28-84		28	165	109	89	84				
ZC29-87		29	168	112	92	87				
ZC30-90	ZCMT12T304SP	30	171	115	95	90	32	BFTX 05085	TRX20	
ZC31-93		31	174	118	98	93				
ZC32-96		32	177	121	101	96				
ZC33-99		33	180	124	104	99				
ZC34-10	ZCMT150408	34	183	127	107	102	40	BFTX 05085	TRX20	
ZC35-10		35	186	130	110	105				
ZC36-10		36	189	133	113	108				
ZC37-11		37	192	136	116	111				
ZC38-11	ZCMT150406SP	38	195	139	119	114	40	BFTX 05085	TRX20	
ZC39-11		39	198	142	122	117				
ZC40-12		40	201	145	125	120				
C40 ZC41-12		ZCMT200608	41	213	148	128				123
	ZC42-12		42	216	151	131	126			
ZC43-12	ZCMT200608	43	219	154	134	129	40	BFTX 06012	TRX25	
ZC44-13		44	222	157	137	132				
ZC45-13		45	225	160	140	135				
ZC46-13		46	228	163	143	138				
ZC47-14	ZCMT200608	47	231	166	146	141	40	BFTX 06012	TRX25	
ZC48-14		48	234	169	149	144				
ZC49-14		49	237	172	152	147				
ZC50-15		50	240	175	155	150				
ZC51-15	ZCMT200608	51	243	178	158	153	40	BFTX 06012	TRX25	
ZC52-15		52	246	181	161	156				
ZC53-15		53	249	184	164	159				
ZC54-16		54	252	187	167	162				
ZC55-16	ZCMT200608	55	255	190	170	165	40	BFTX 06012	TRX25	
ZC56-16		56	258	193	173	168				
ZC57-17		57	261	196	176	171				
ZC58-17		58	264	199	179	174				
ZC59-17	ZCMT200608	59	267	202	182	177	40	BFTX 06012	TRX25	

G