

KIGM

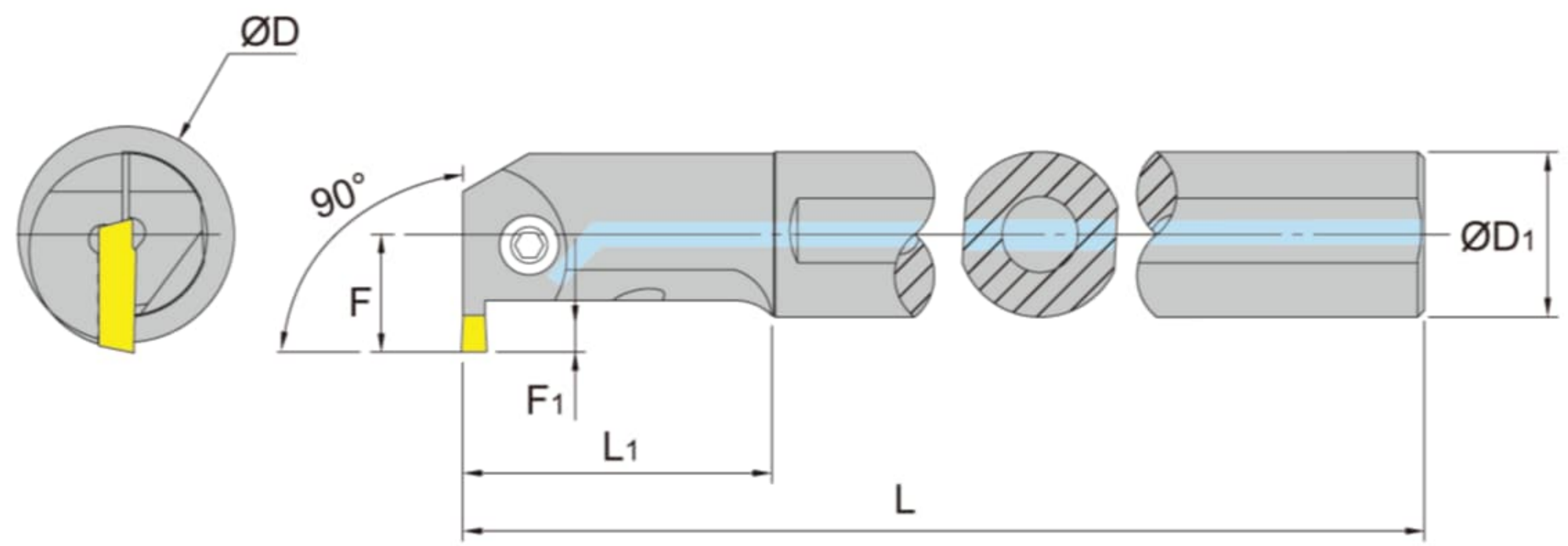
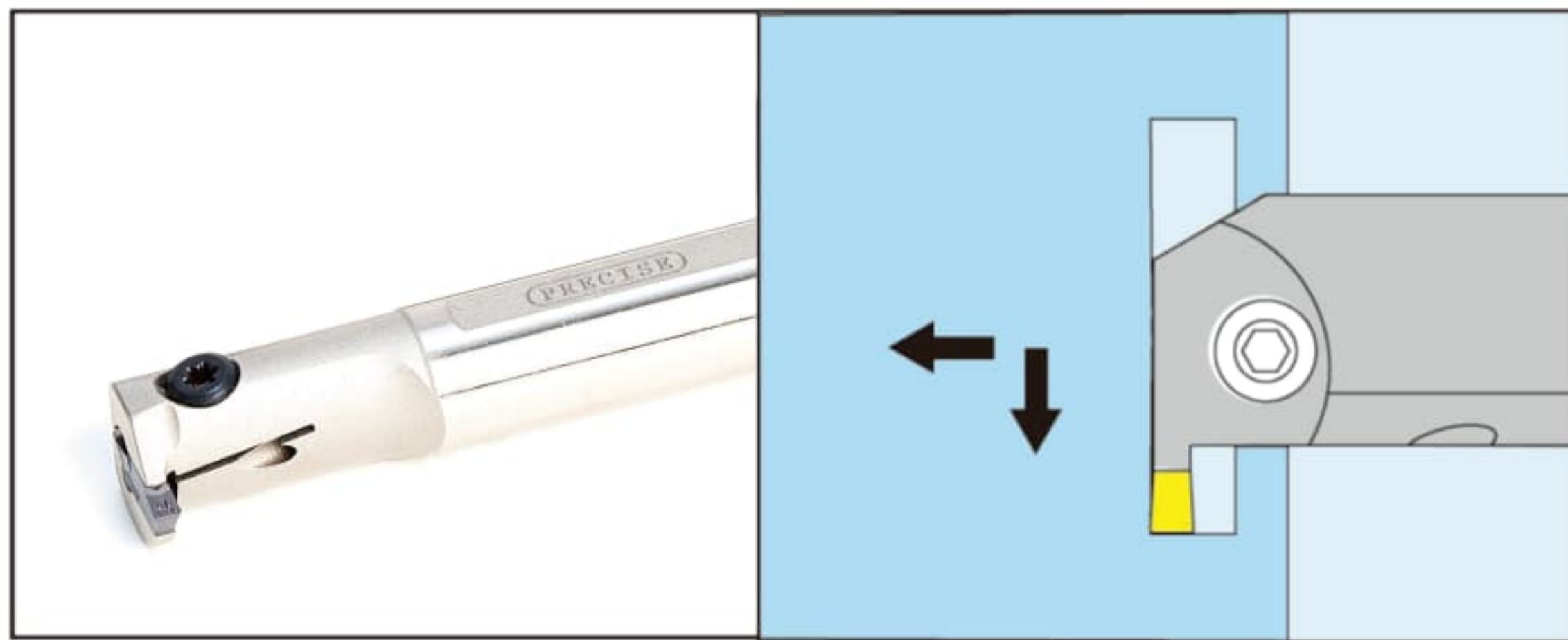

■ Right hand tool holder shown.(For Kyocera Insert)

	Order number	Insert number	Dimensions (mm)						Screw	Wrench	
			$\varnothing D_1$	$\varnothing D$	F	F_1	L_2	L			L_1
COOLANT 中心注水	A16M KIGMR-3V	GMM3015-04V	16	20	11.5	5.5	4.0	150	25	BFTX0511	TRX15
	A20Q KIGMR-3	GMM 3020-04 3020-15R/4020-4	20	25	14.5	7.0	5.0	180	32	BX0514	LH-040
	A25R KIGMR-3		25	32	19	8.5	7.0	200	40	BX0520	LH-040
	A32X KIGMR-3		32	40	23	11	7.0	220	50	BX0620	LH-050
	A25R KIGMR-5	GMM 5020-04 6020-04	25	32	19	8.5	5.0	200	40	BX0520	LH-040
	A32X KIGMR-5		32	40	23.5	11	7.0	220	50	BX0620	LH-050

E

TGIR

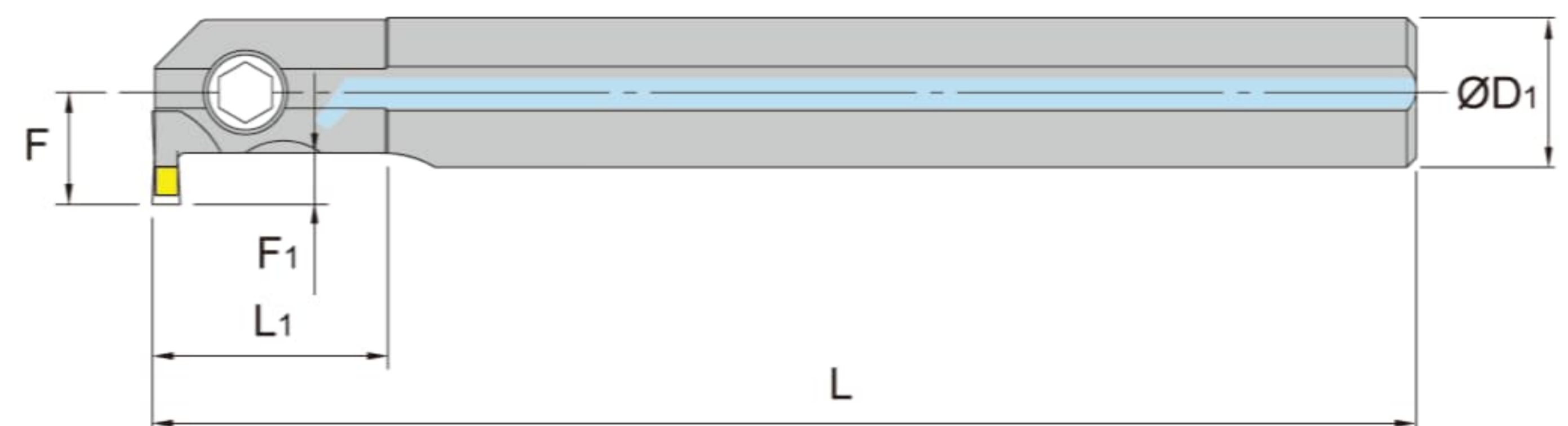
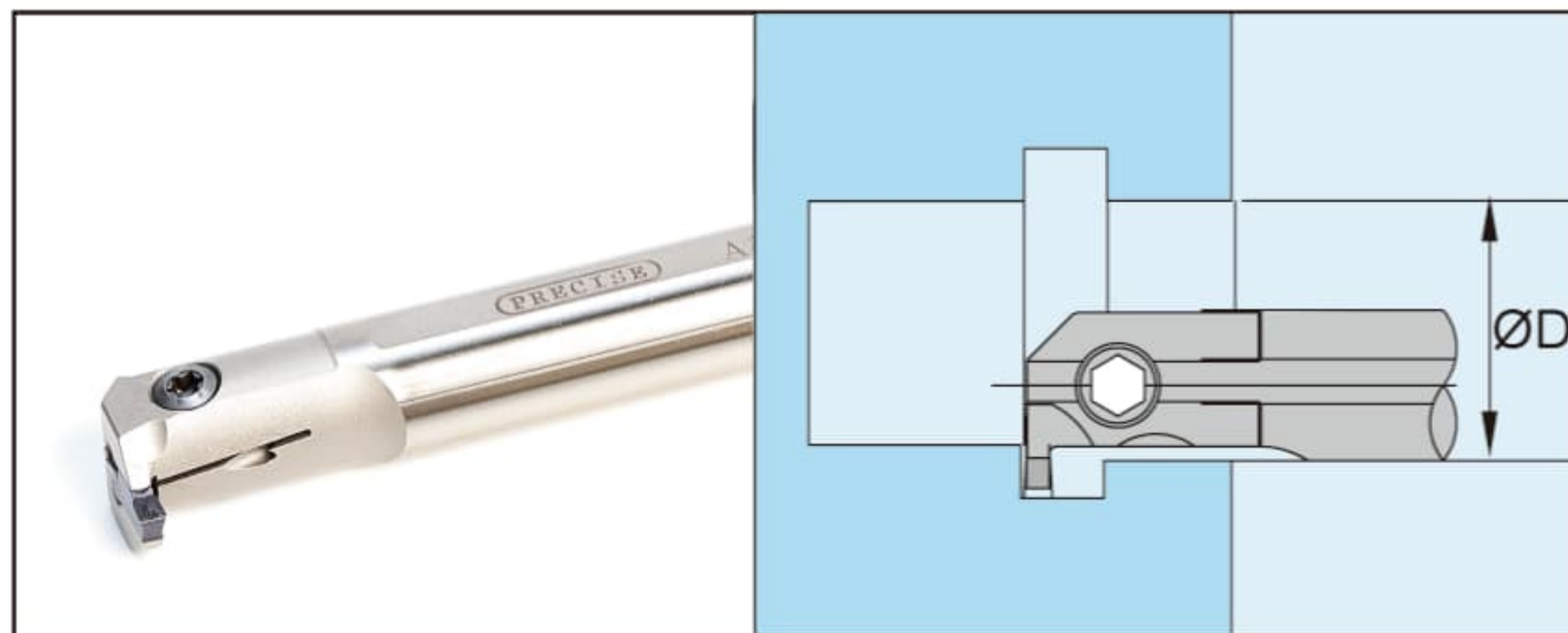

■ Right hand tool holder shown.(For Iscar Insert)

	Order number	Insert number	Dimensions (mm)						Screw	Wrench
			$\varnothing D$	$\varnothing D_1$	F	F_1	L	L_1		
COOLANT 中心注水	A16N TGIR-3	TGMF-302 TGMF-304 TGMF-315	20.5	16	12.0	5.5	160	25	BFTX0511	TRX15
	A20Q TGIR-3		25	20	14.2	5.5	180	32	BX0514	LH-040
	A25R TGIR-3		32	25	18.8	8.0	200	40	BX0516	LH-050
	A25R TGIR-4	TGMF-402 TGMF-508	32.5	25	19.5	8.5	200	40		
	A32X TGIR-4	TGMF-404 TGMP-506	42	32	25.5	11	220	50	BX0620	
	A32X TGIR-6	TGMP-420 TGMP-525	47	32	29.0	17.5	220	50		
	A40T TGIR-6	TGMF-635-08 TGMF-630 TGMF-630	47	40	35.2	17.5	300	60		

GEHIR

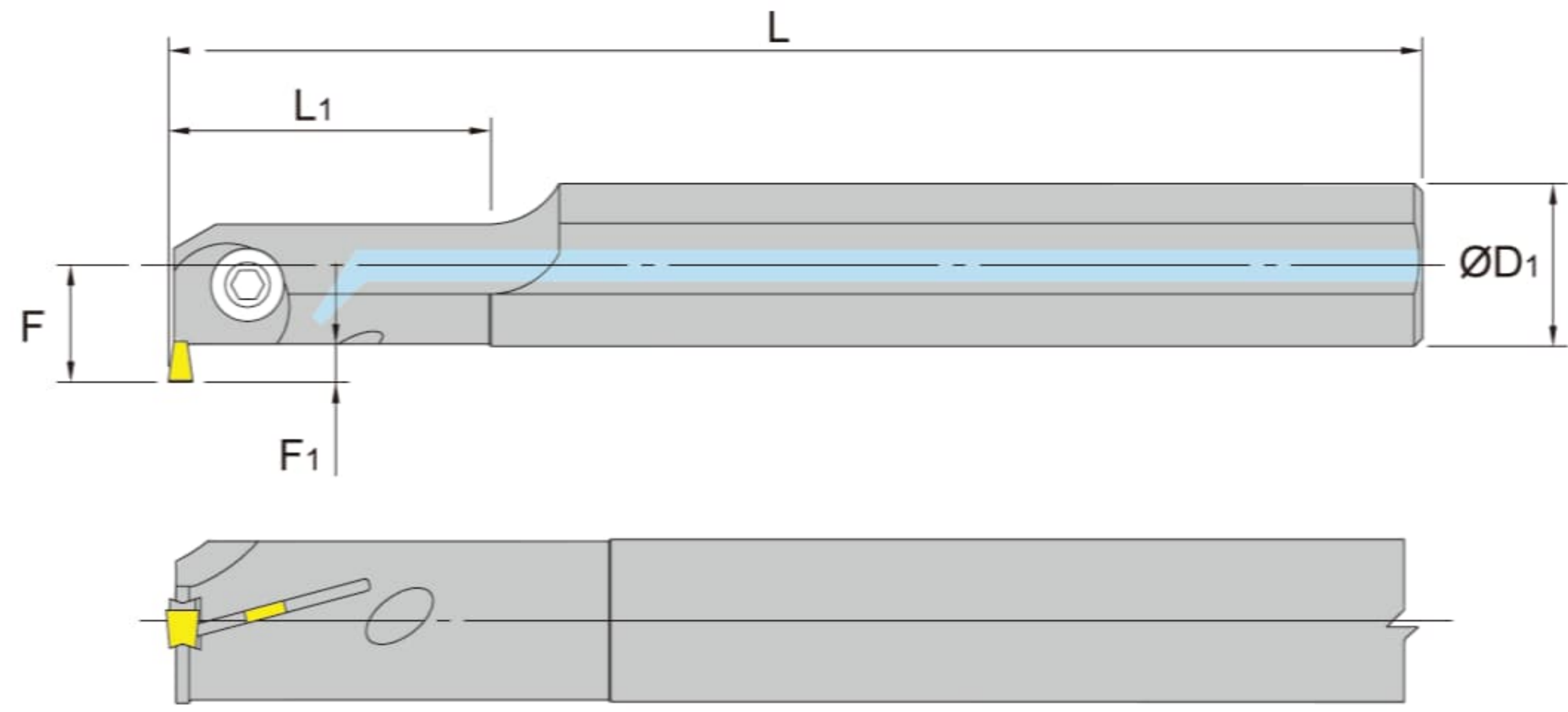
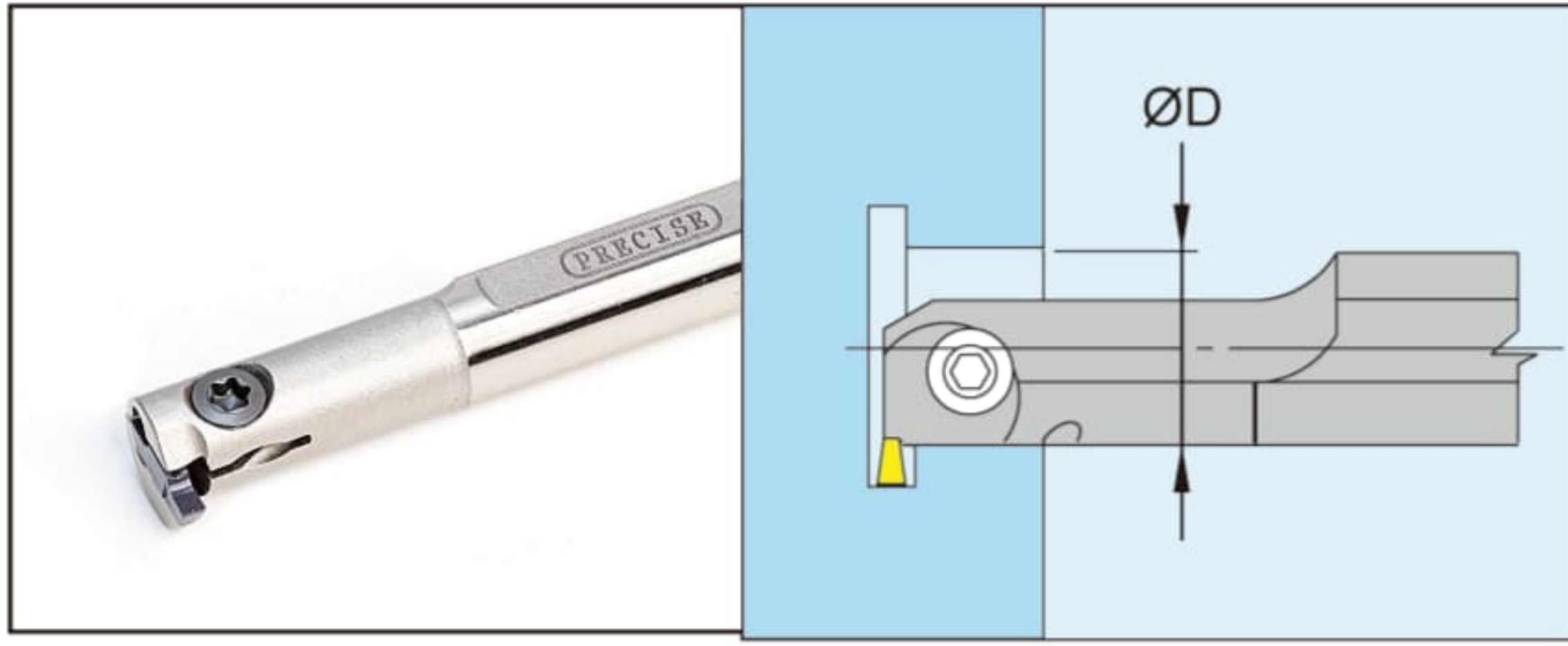

■ Right hand tool holder shown.(For Iscar Insert)

	Order number	Insert number	Dimensions (mm)					Screw	Wrench	
			ØD1	ØD	F	F1	L			L1
COOLANT	A10K GEHIR-12.5	GEMI 3.00 GEPI 1.00/1.96 GEPI 2.00/3.18	10	12.5	7.5	2.4	125	25	BFTX0407	TRX15
	A12M GEHIR-14		12	14	9.1	2.6	150	35		
	A16N GEHIR-16		16	16	11	3.0	160	40	BFTX0410	
	A16N GEHIR-19		16	19	11	3.0	160	—		

E

GHIR

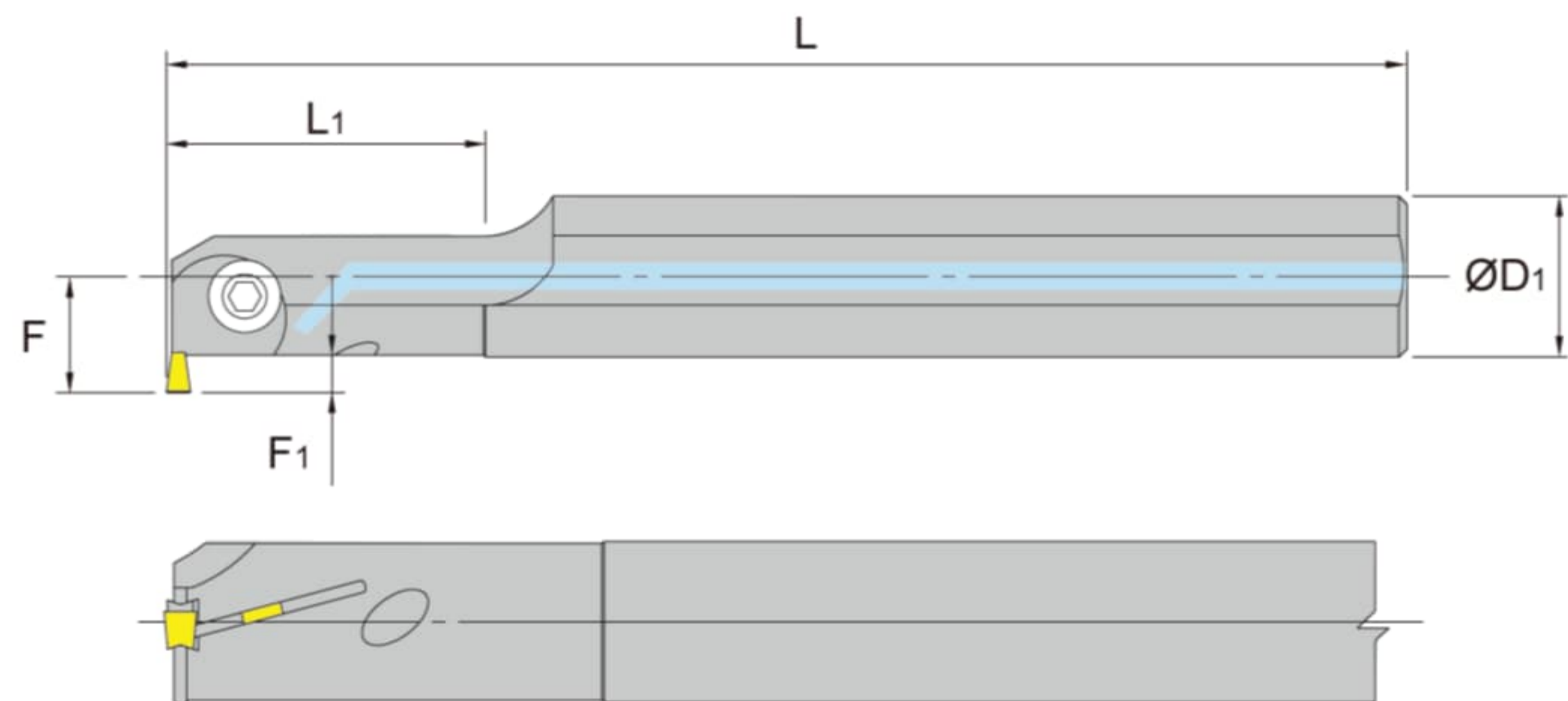
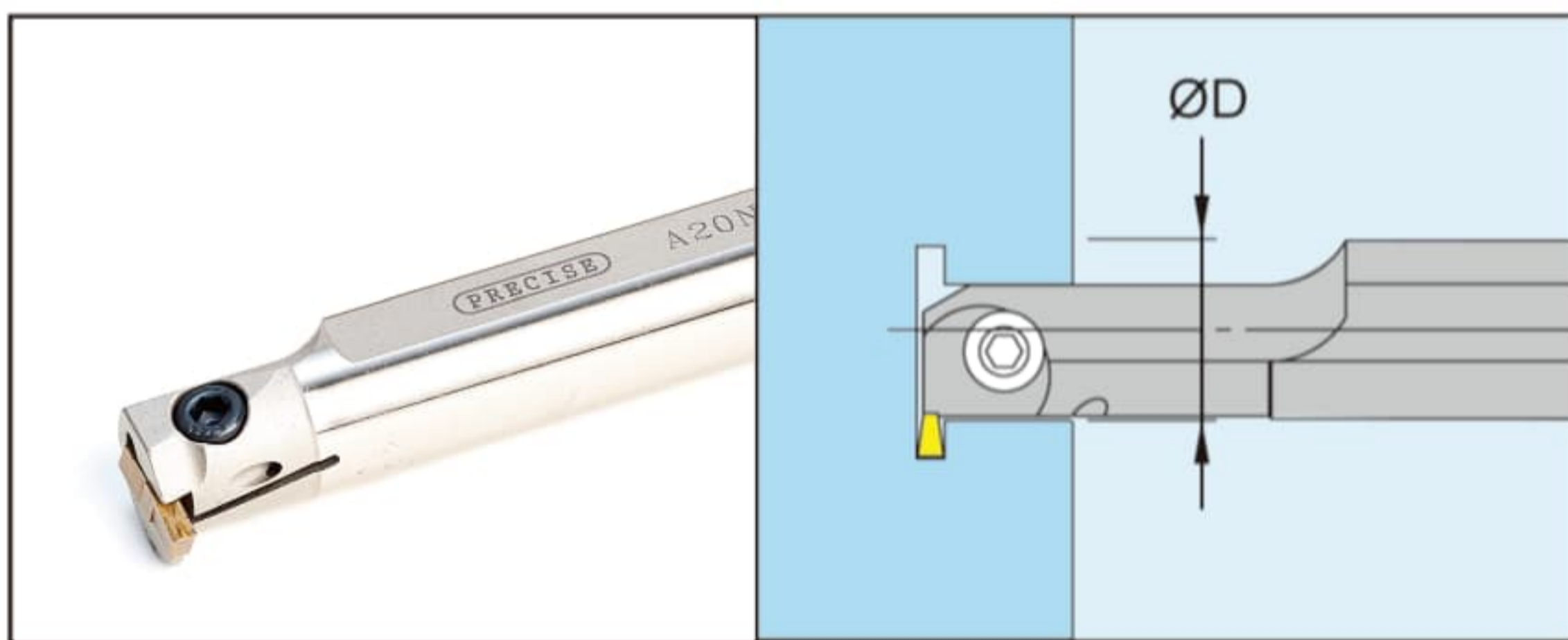

■ Right hand tool holder shown.(For Iscar Insert)

	Order number	Insert number	Dimensions (mm)					Screw	Wrench	
			ØD	ØD1	F	F1	L			L1
COOLANT 冷却水	A20N GHIR 20-3	GIM / GIP GIMIY 304/404 TIPI 3.4/5.4 GIPI 1.57/6.35 GIFI 4.23/5.28	20	20	14.5	4.5	160	20	BX0515	LH-040
	A20R GHIR 2020-3		20	20	14.5	4.5	200	40		
	A25R GHIR 25-4		25	25	17.5	5.0	200	50		
	A32S GHIR 32-4		39	32	22.8	6.5	250	—		
	S32S GHIR 32-4		39	32	22.8	6.5	250	—		

GYIR/L

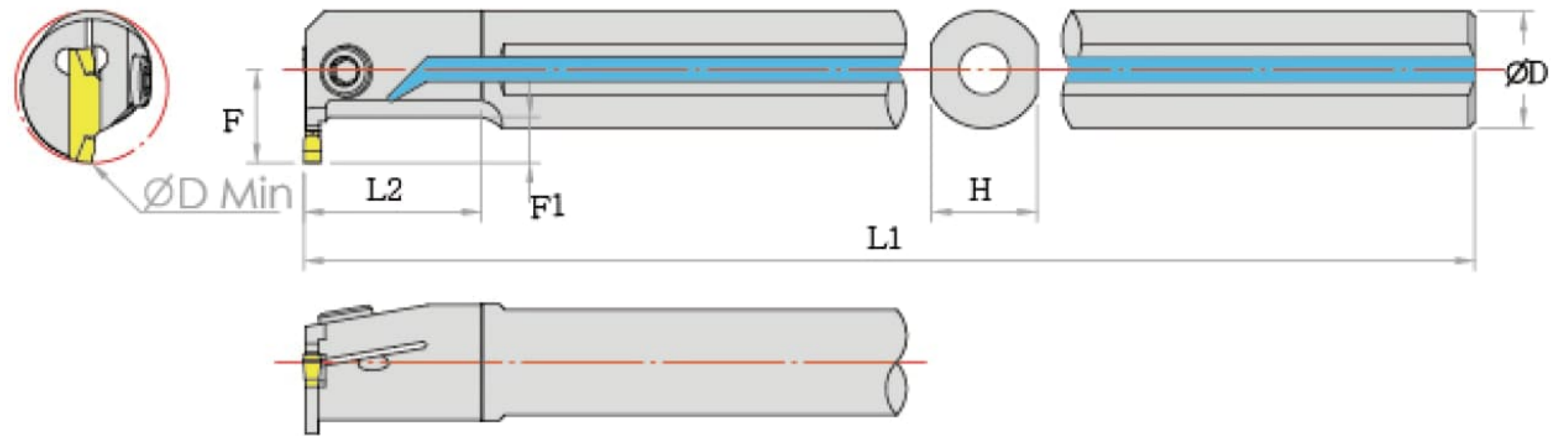
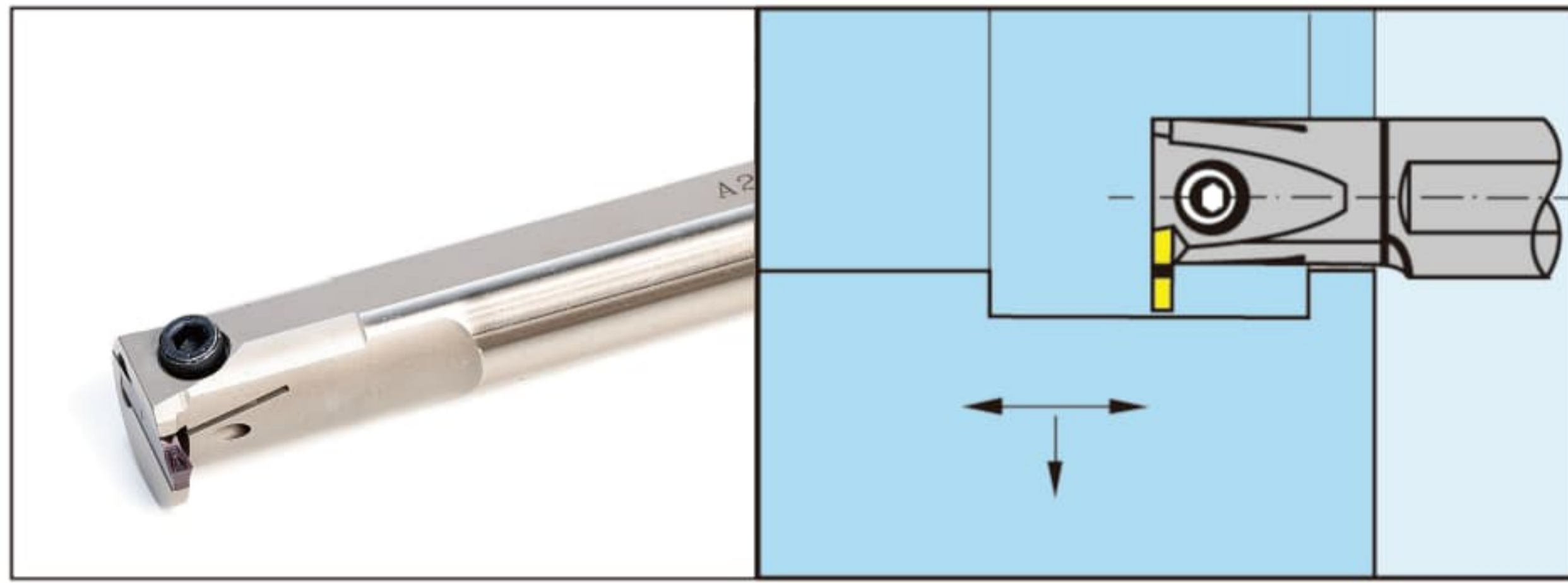

■ Right hand tool holder shown.(For Mitsubish Insert)

	Order number	Insert number	Dimensions (mm)					Min cutting diameter	Screw	Wrench
			ØD	F	F1	L1	L2			
COOLANT 中心出水	A20Q GYIR/L-2T06	GY2M 0200D020N GS/GM/GFGS (0239E/0250E) R/L05-GM	20	14.5	6	180	40	25	BX0520	LH-040
	A25R GYIR/L-2T09		25	17	9	200	50	32		
	A20Q GYIR/L-3T06	GY2M 0300F020N GS/GM/GFGS/MS MM/BM/R/L05-GM (0318F)	20	14.5	6	180	40	25		
	A25R GYIR/L-3T09		25	17	9	200	50	32		
	A32S GYIR/L-3T11		32	26	11	250	60	40		
	A25R GYIR/L-4T09	GY2M 0400G020N GS/GM/GFGS/MS/M M/BM/R/L05-GM	25	17	9	200	50	32		
	A32S GYIR/L-4T11		32	26	11	250	60	45		
	A40T GYIR/L-4T18		40	35	18	300	80	60		

E

TTIR/L

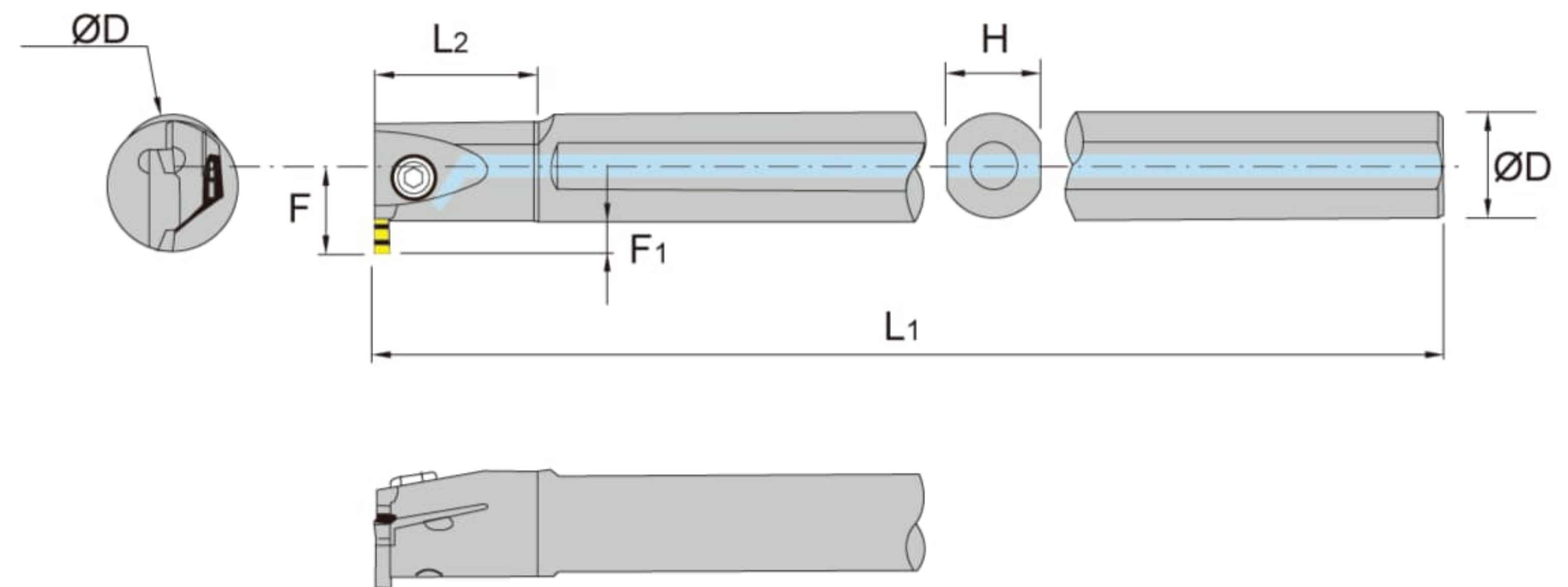
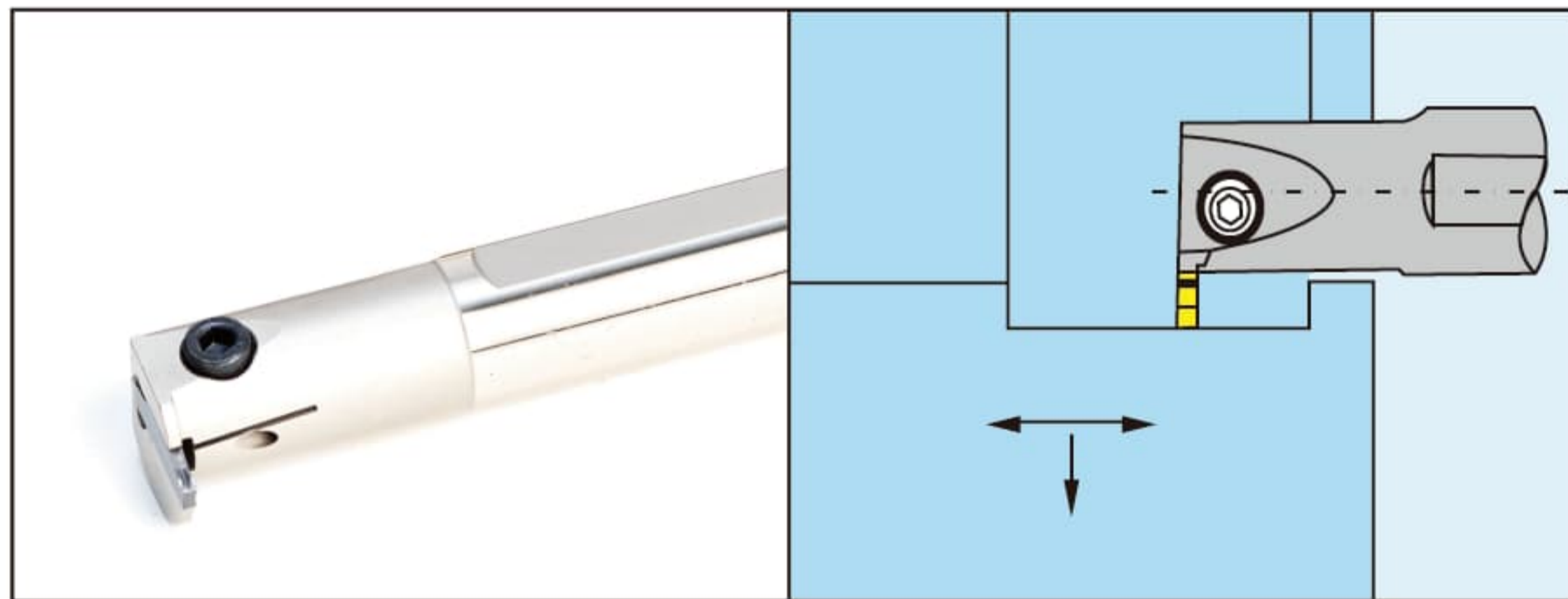

■ Right hand tool holder shown.(For Taegutec Insert)

	Order number	Insert number	Dimensions (mm)					Min cutting diameter	Screw	Wrench
			ØD	F	F1	L1	L2			
COOLANT 中心出水	A20Q TTIR/L-2T06	TDJ/C TSJ/C TDT TDG TDXU4E	20	16	6	180	40	25	BX0520	LH-040
	A20Q TTIR/L-3T06		20	16	6	180	40	25		
	A25R TTIR/L-2T06		25	23	7	200	50	25		
	A25R TTIR/L-3T06		25	18.5	6	200	50	25		
	A32S TTIR/L-3T07		32	23	7	250	60	31		
	A25R TTIR/L-4T09		25	18.5	9	200	50	25		
	A32S TTIR/L-4T09		32	23	9	250	60	31		
	A40T TTIR/L-4T09		40	27	9	300	80	42		

SIGER

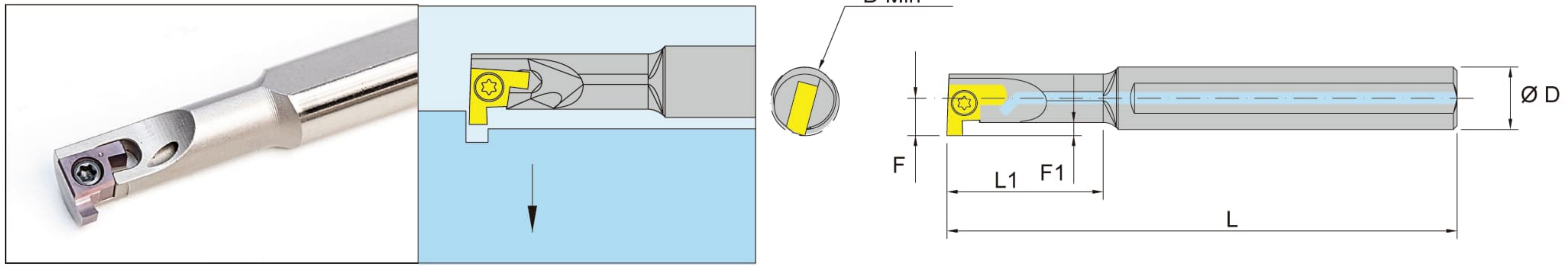

■ Right hand tool holder shown.(For Kyocera Insert)

	Order number	Insert number	Dimensions (mm)					Min cutting diameter	Screw	Wrench
			ØD	F	F1	L	L1			
AHSS	AH08H SIGER-A08	GER 100~200A(R)	8	4.8	1.5	100	20	8	BFTX0205	TRX06
	AH10K SIGER-B10	GER 100/120/125/145BR 150/200/250/300	10	6.2	2.2	125	25	10	BFTX02206	TRX07
	AH10K SIGER-B12		10	7		125	30	12		
STEEL	A08H SIGER-A08	GER 100~200A(R)	8	4.8	1.5	100	20	8	BFTX0205	TRX06
	S08H SIGER-B10	GER 100/120/125/145BR 150/200/250/300	8	6.2	2.2	100	15	10	BFTX02206	TRX07
	S10K SIGER-B12		10	7		125	15	12		

PCDIR/L 内径切槽刀架

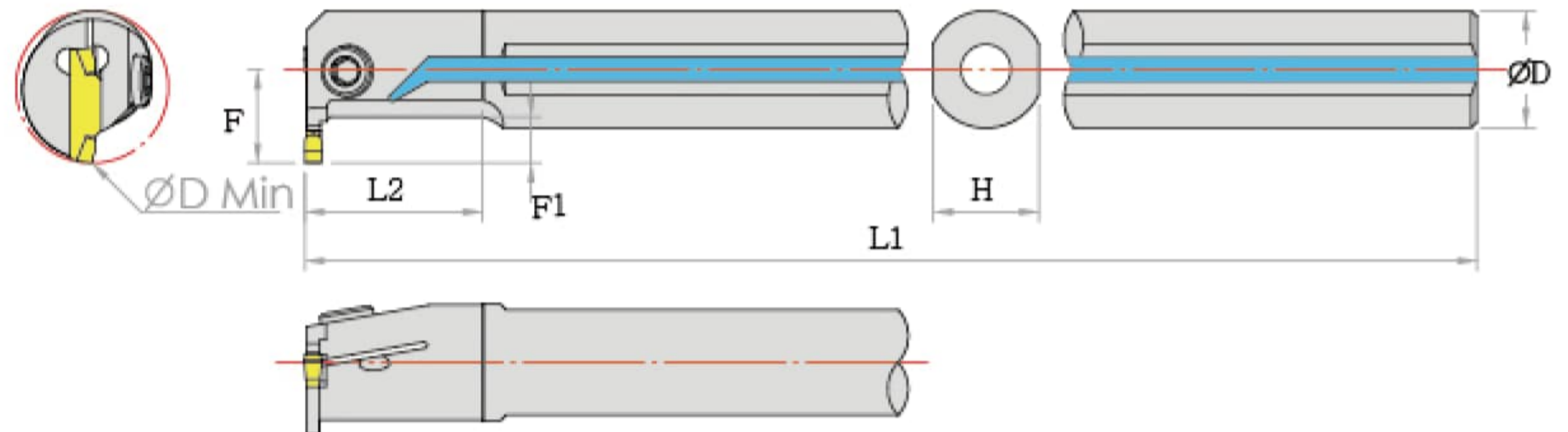

■ Right hand tool holder shown.(For Precise Insert)

	Order number	Insert number	Dimensions (mm)					Min cutting diameter	Screw	Wrench		
			W	H	B	L	T					
COOLANT 中心注水	A20Q PCDIR/L 2T06	CD 200R/L/N 250R/L/N (F1/T/M1)	20	15	6	180	40	25	BX0520	LH 040		
	A25R PCDIR/L 2T07		25	21.5	7	200	50	32				
	A20Q PCDIR/L 3T06	CD 300R/L/N (F1/T/M1/R)	20	15	6	180	40	25			BX0620	LH 050
	A25R PCDIR/L 3T07		25	21.5	7	200	50	32				
	A32S PCDIR/L 3T11	CD 400/N (F1/T/M1/R)	32	27	11	250	60	40	BX0520	LH 040		
	A25R PCDIR/L 4T09		25	21.5	9	200	50	32	BX0620	LH 050		
	A32S PCDIR/L 4T11		32	27	11	250	60	40				
	A40T PCDIR/L 4T11	40	38	11	300	80	50					

