

GYHR/L 外徑霸王刀架

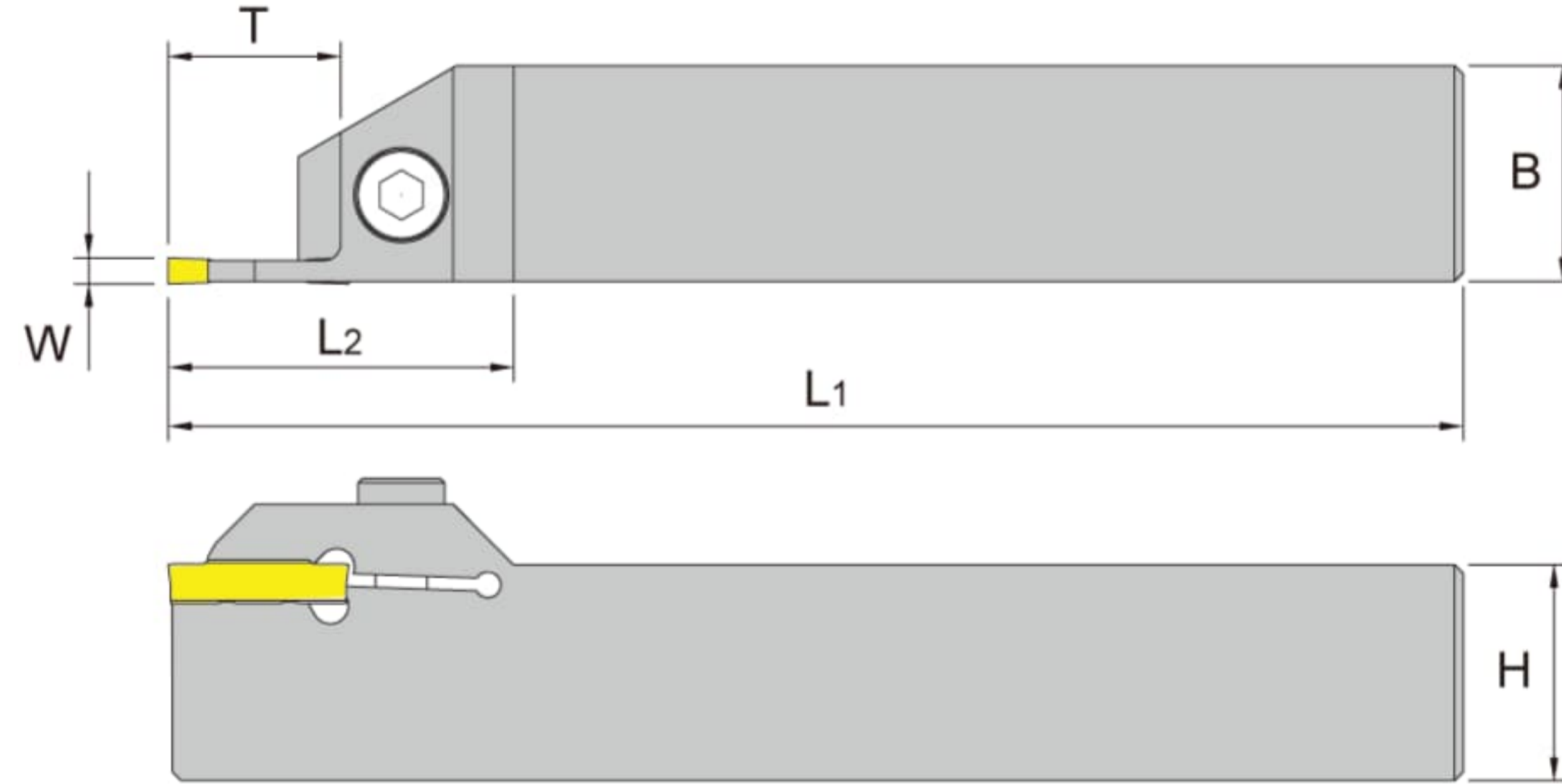
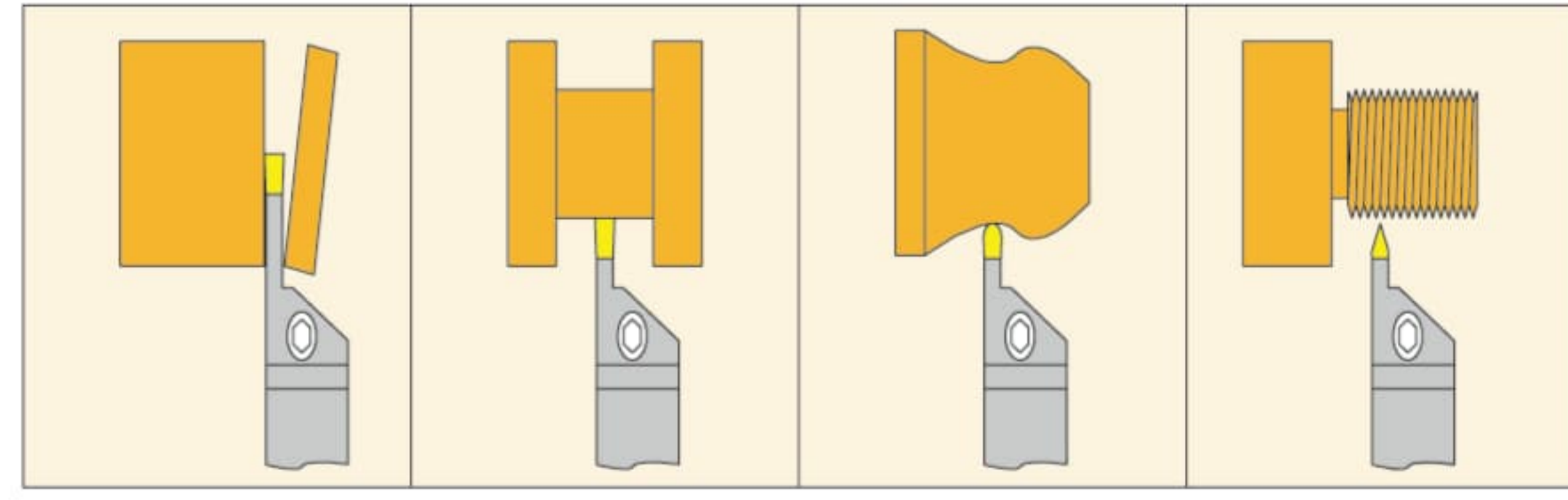
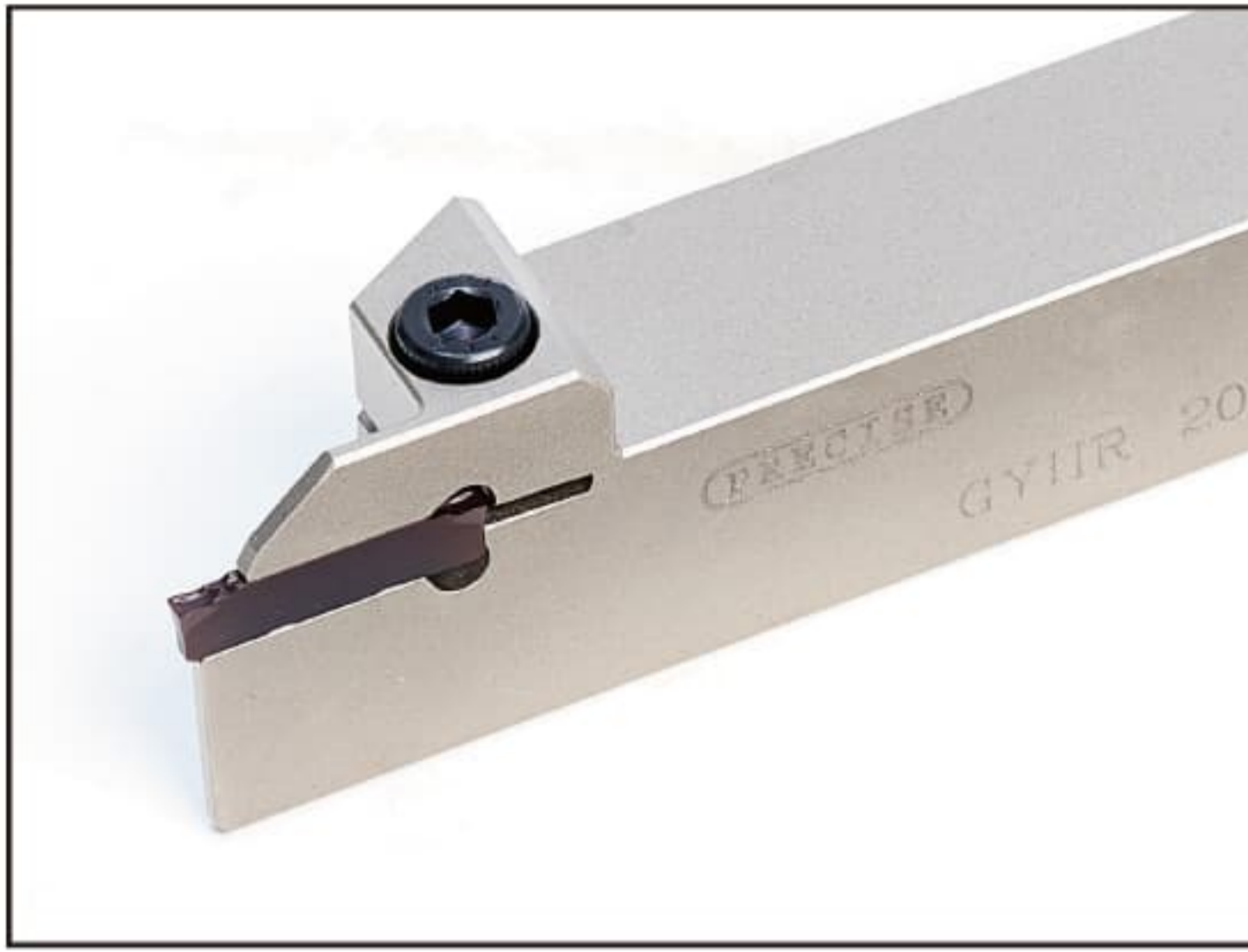

C

■ Right hand tool holder shown. (For Mitsubishi Insert)

Order number	Insert number	Dimensions (mm)						Screw	Wrench
		W	H	B	L1	L2	T		
GYHR/L 1616K-2T09	GY2M 0200D020N GS/GM/GFGS R/L05-GM (0239E/0250E)	2	16	16	125	40	9	BX0620	LH-050
2020K-2T09			20	20					
2525M-2T09			25	25					
1616K-3T09	GY2M 0300F020N GS/GM/GFGS/MS MM/BM/R/L05-GM (0318F)	3	16	16	125	40	12	BX0620	LH-050
2020K-3T09			20	20					
2525M-3T12			25	25					
2020K-4T10	GY2M 0400G020N GS/GM/GFGS/MS/ MM/BMR/L05-GM	4	20	20	125	40	10	BX0620	LH-050
2525M-4T10			25	25					
2525M-5T12	GY2M 0500H020N GS/GM/GFGS/MS/MM/ BM/L05-GM(0475H)	5	25	25	150	40	12	BX0620	LH-050
GYHR/L 1616K- 2T17	GY2M 0200D020N GS/GM/GFGS R/L05-GM (0239E/0250E)	2	16	16	125	40	17	BX0520	LH-040
2020K-2T17			20	20					
2525M-2T17			25	25					
1616K-3T20	GY2M 0300F020N GS/GM/GFGS/MS MM/BM/R/L05-GM (0318F)	3	16	16	125	40	20	BX0620	LH-050
2020K-3T20			20	20					
2525M-3T20			25	25					
2020K-4T20	GY2M 0400G020N GS/GM/GFGS/MS/ MM/BM/R/L05-GM	4	20	20	125	40	25	BX0620	LH-050
2525M-4T25			25	25					
2525M-5T25	GY2M 0500H020N GS/GM/GFGS/MS/ MM/BM/R/L05-GM (0475H)	5	25	25	150	40	25	BX0620	LH-050

PCDR/L 外徑切斷刀架

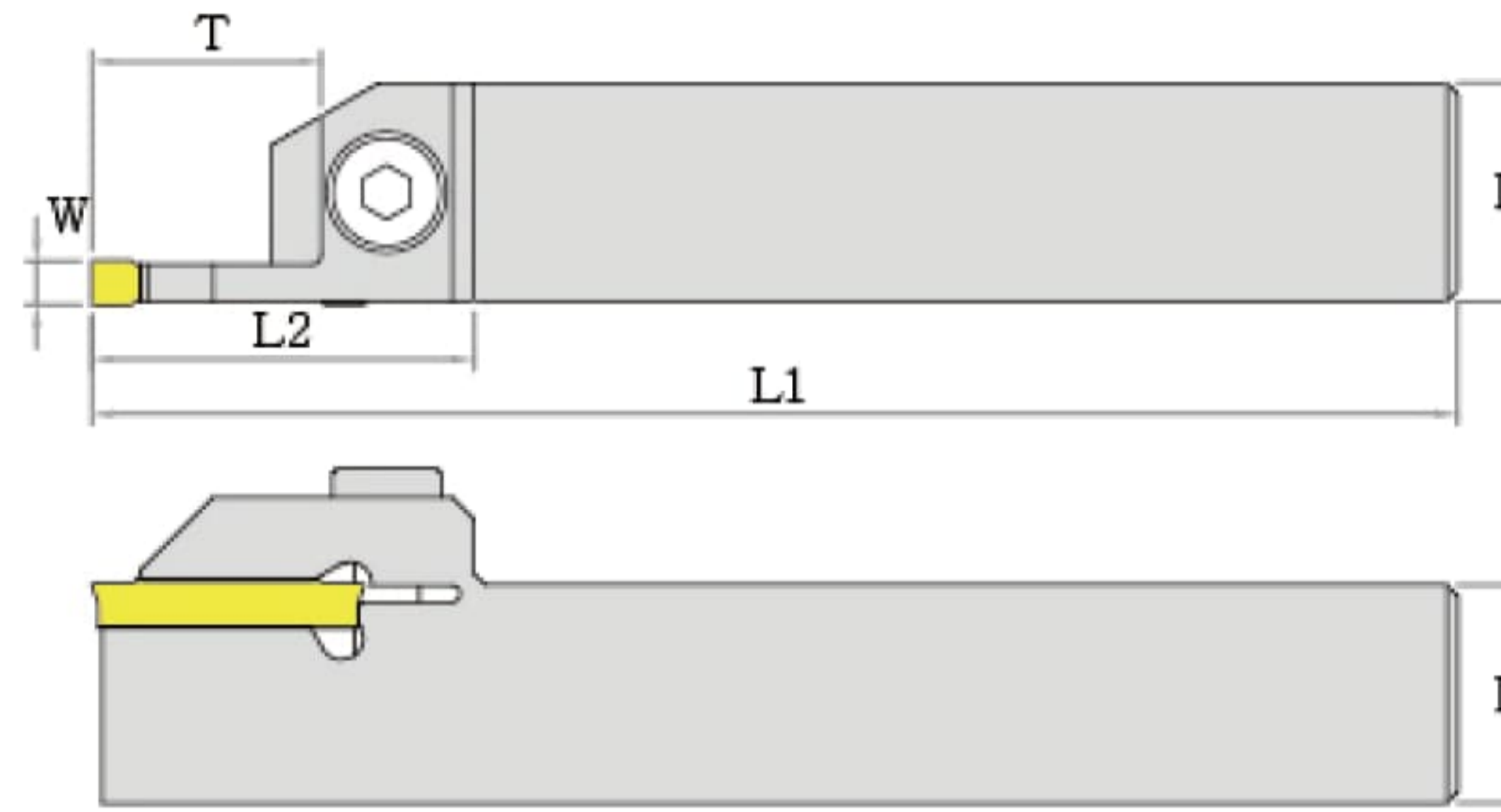
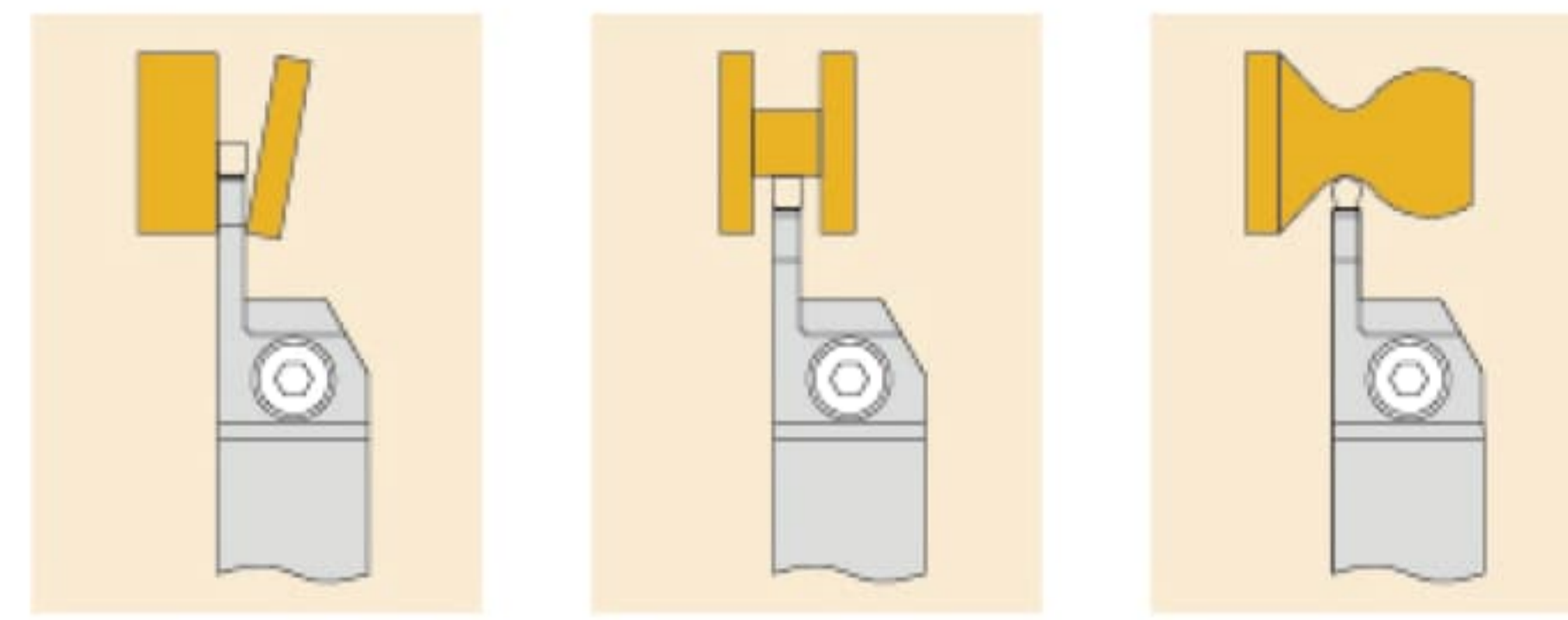
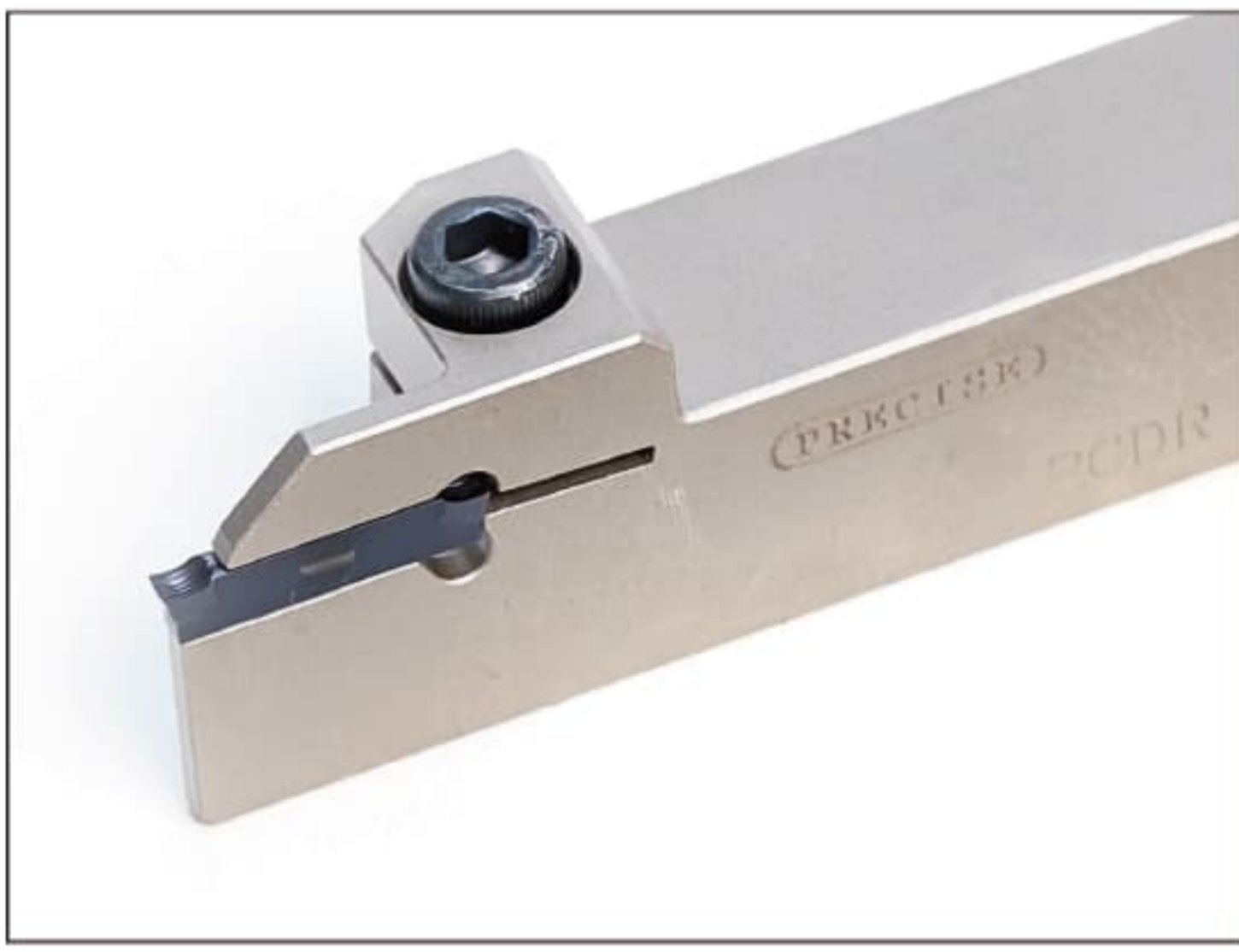

■ Right hand tool holder shown.(For Precise Insert)

Order number	Insert number	Dimensions (mm)					Screw	Wrench
		W	H	B	L	T		
PCDR/L 1212K 2T12 SH	CD 200R/L/N 250R/L/N (F1/T/M1)	2	12	12	125	12	BFTX0407	TRX 15
1616K 2T17		2	16	16	125	17	BX0520	LH 040
2020K 2T17		2	20	20	125	17	BX0620	LH 050
2525M 2T17		2	25	25	150	17		
1616K 2T14 SH		2	16	16	125	14	BX0520	LH 040
1616K 3T14 SH	3	16	16	125	14			
1616K 3T20	3	16	16	125	20			
2020K 3T09	CD 300R/L/N (F1/T/M1/R)	3	20	20	125	9	BX0620	LH 050
2020K 3T20		3	20	20	125	20		
2525M 3T09		3	25	25	150	9		
2525M 3T20		3	25	25	150	20		
2020K 4T10		CD 400/N (F1/T/M1/R)	4	20	20	125		
2020K 4T20	4		20	20	125	20		
2525M 4T10	4		25	25	150	20		
2525M 4T20	4		25	25	150	20		
2525M 5T12	CD 500/N (F1/T/M1/R)	5	25	25	150	12	BX0620	LH 050
2525M 5T25		5	25	25	150	25		



R



T



M1



F1

TGTR/L **NEW**

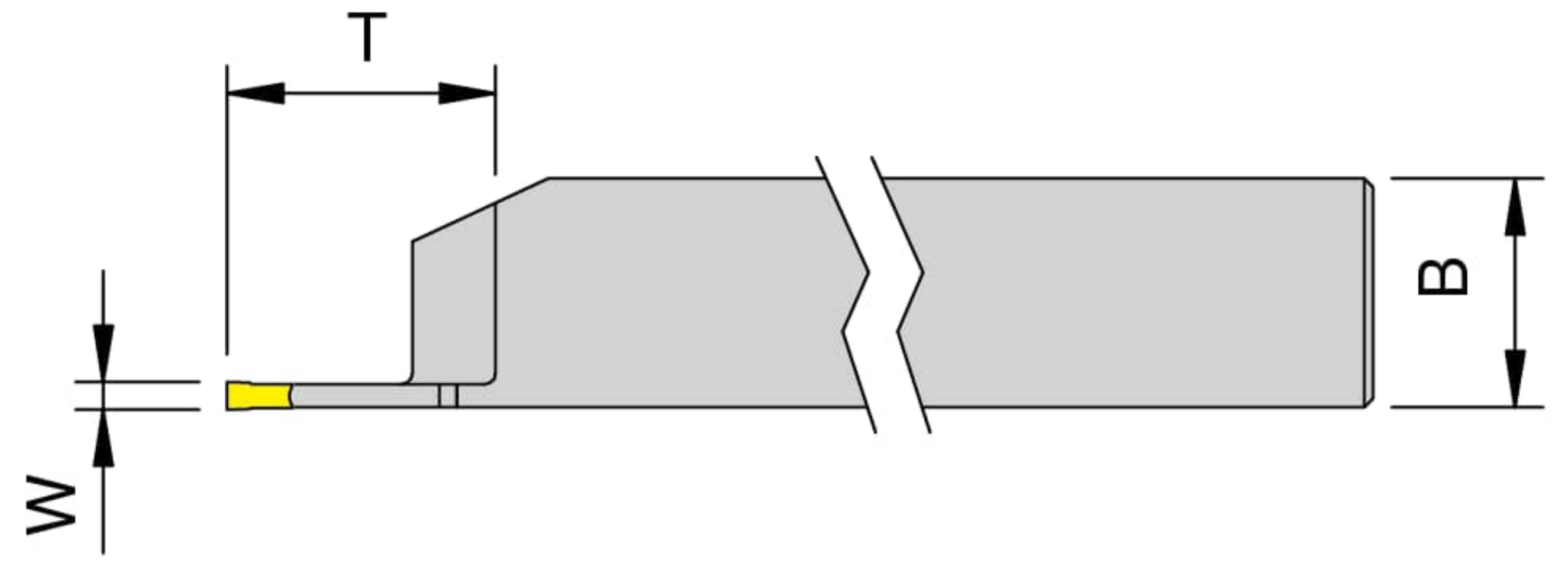
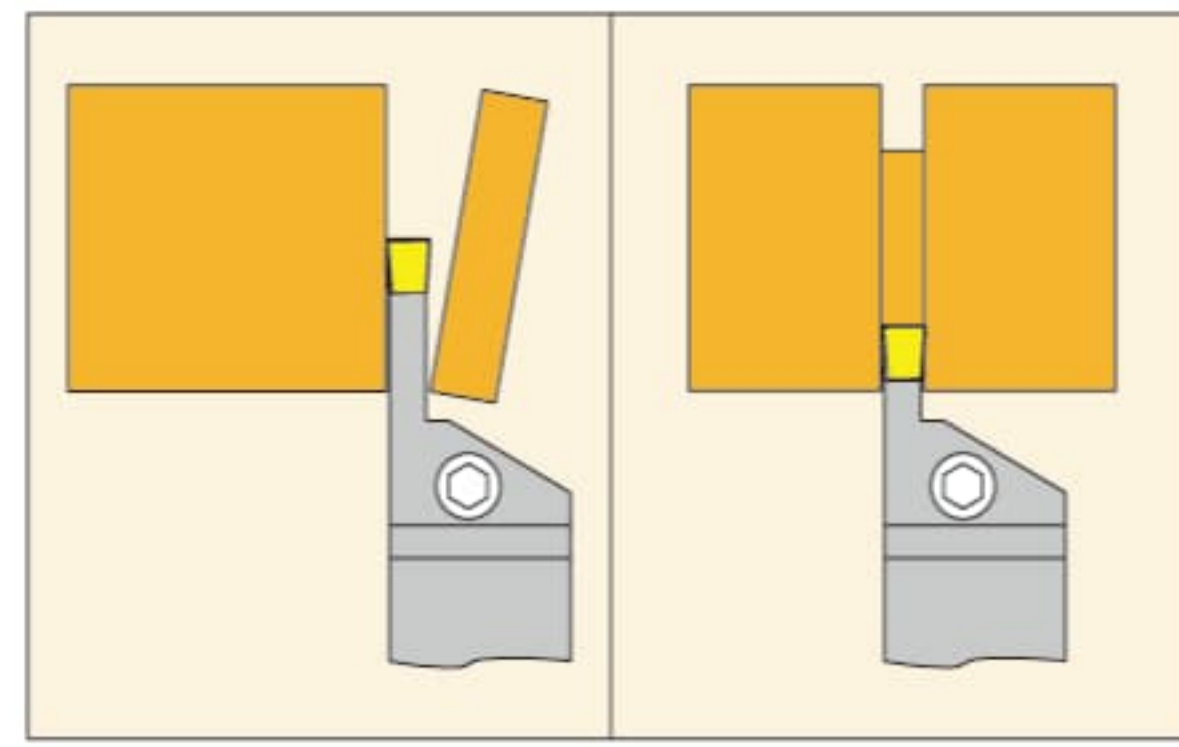
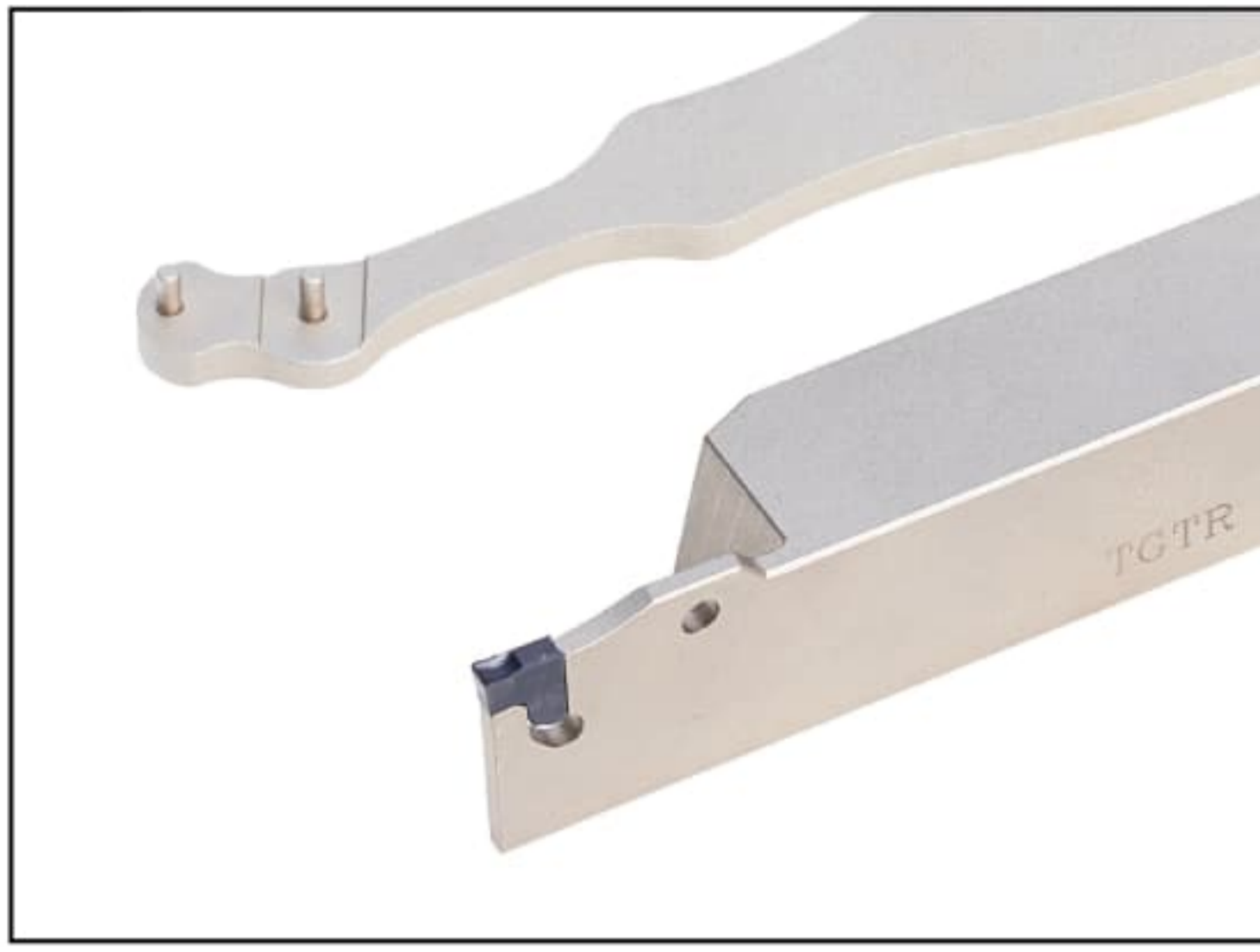

C

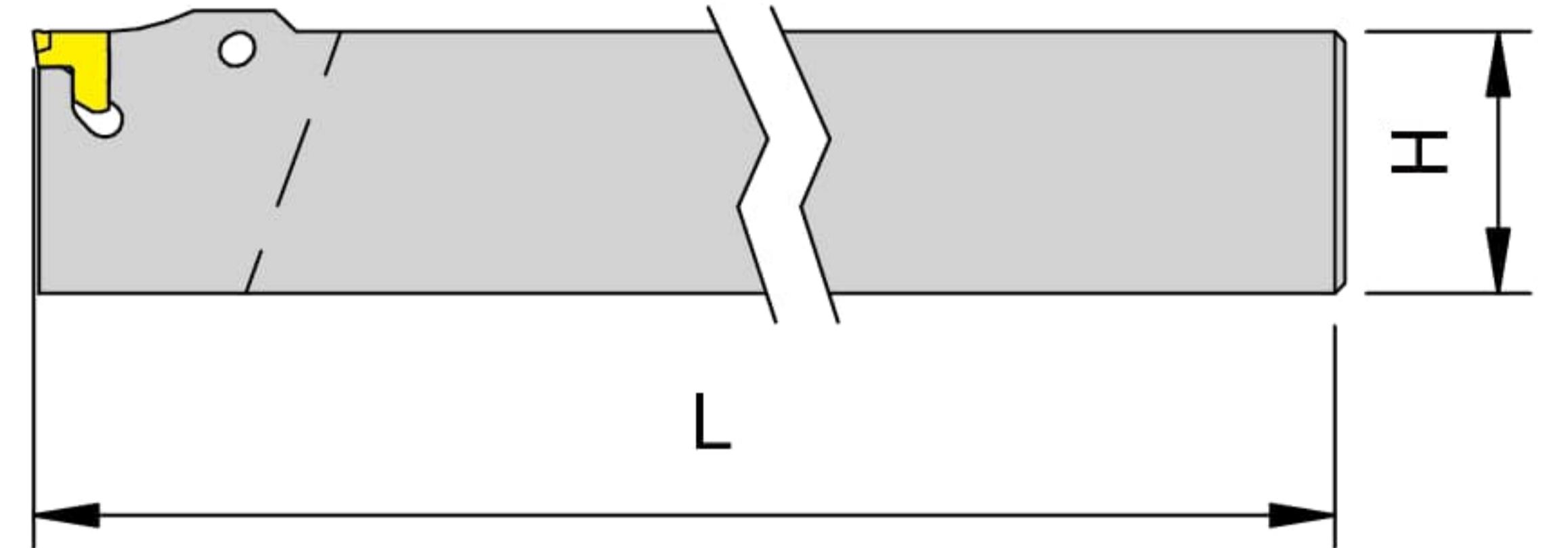
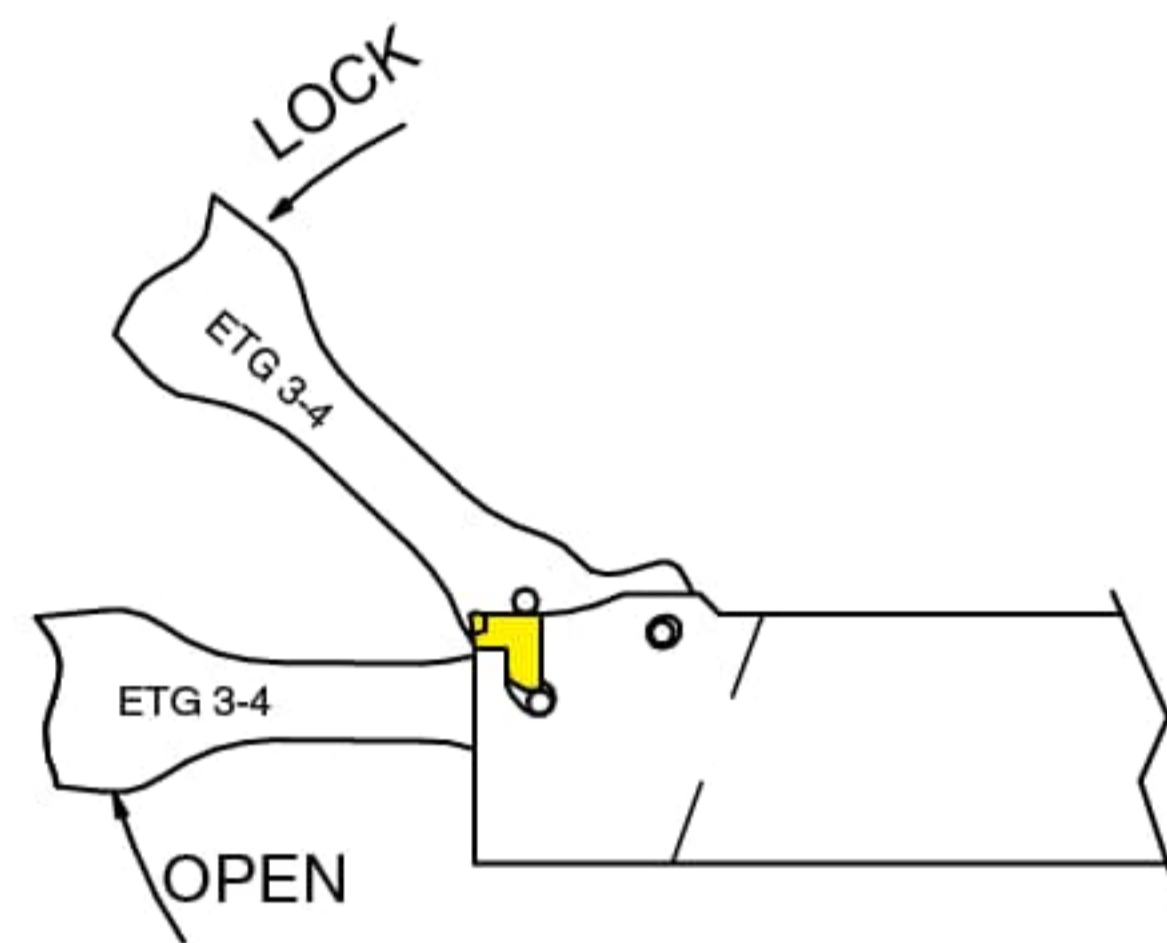
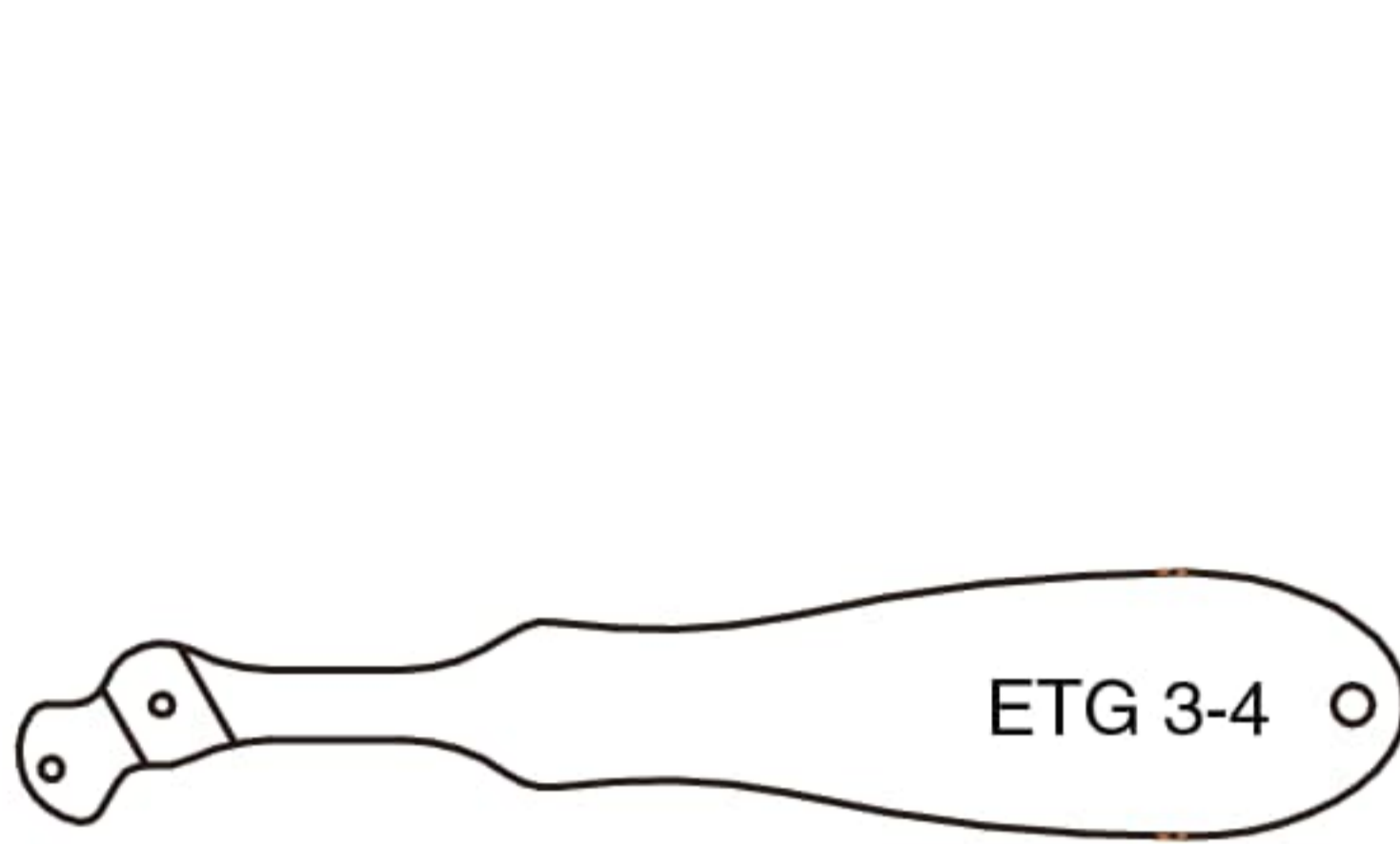

■ Right hand tool holder shown.(For Iscar Insert)

Order number	Dimensions (mm)				Insert number	Wrench
	HxB	L	T	W		
TGTR/L 2020K-3-IQ	20	125	27	2.4~3.5	TAGR/L 2.4~3.5	ETG 3-4
TGTR/L 2525M-3-IQ	25	150	27			

TGFH **NEW**

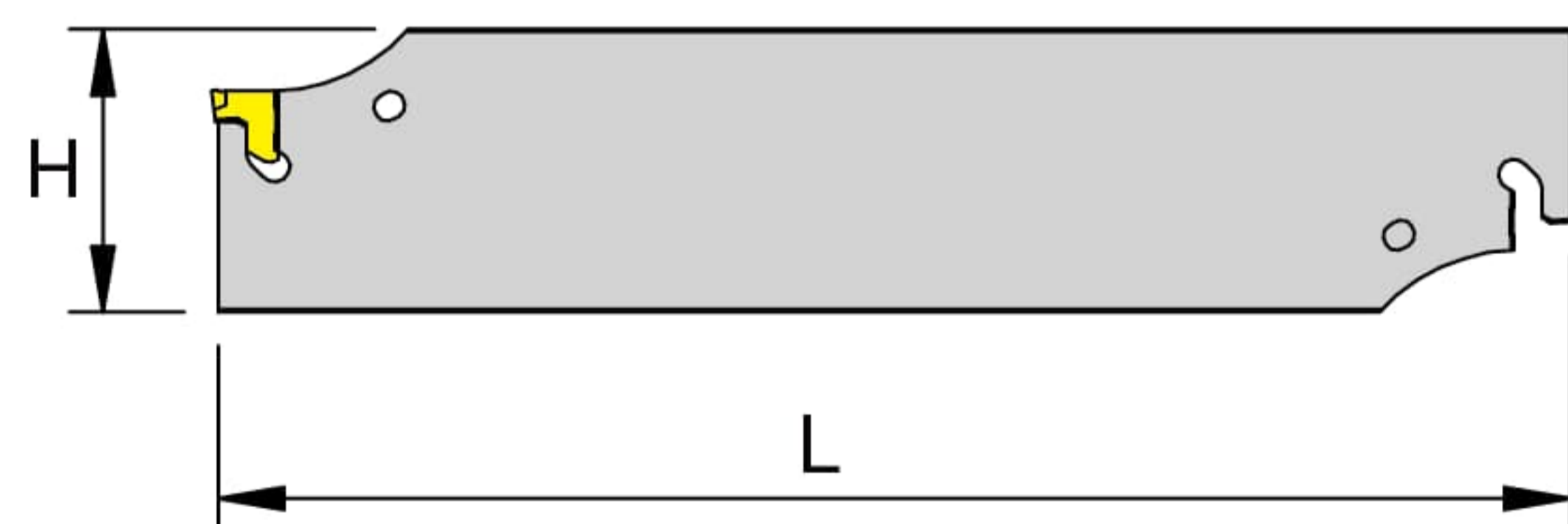
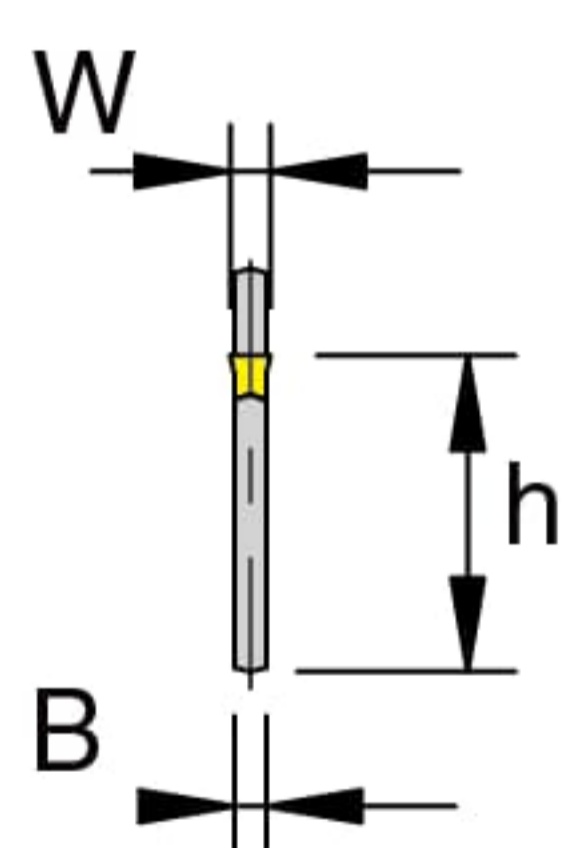

■ (For Iscar Insert)

Order number	Dimensions (mm)					Insert number	Wrench
	h	L	H	W	B		
TGFH 26-3	20	110	26	3	2.4	TAGR/L 2.4~3.5	ETG 3-4
TGFH 32-3	25	150	32	3	2.4		

KGDR/L NEW

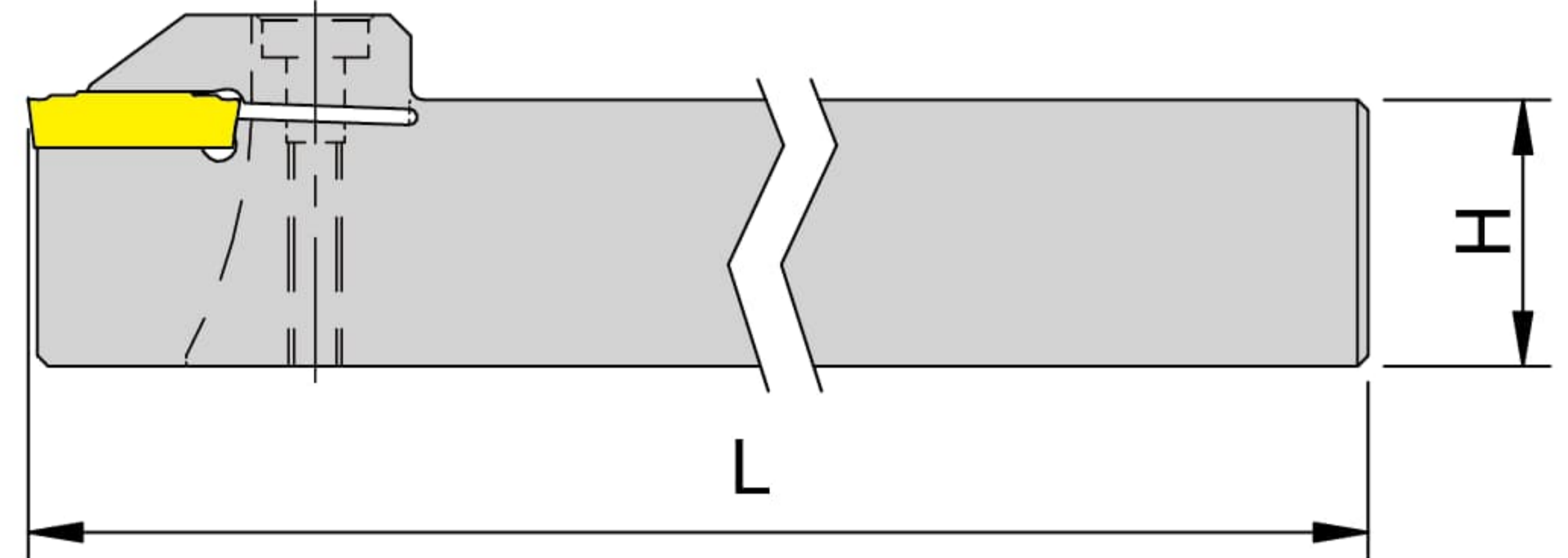
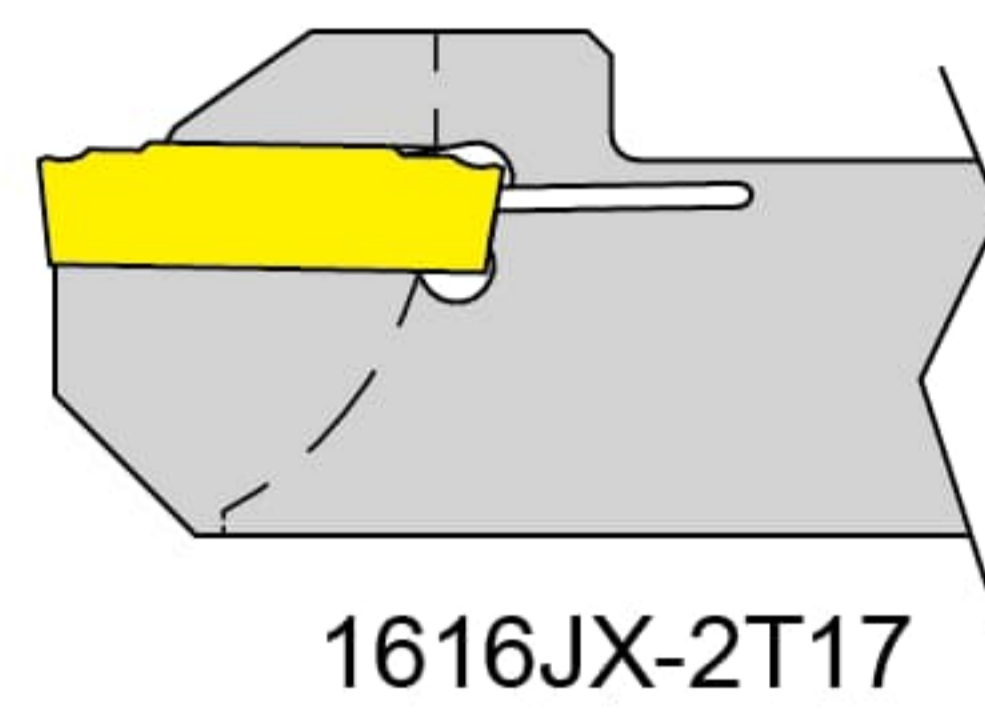
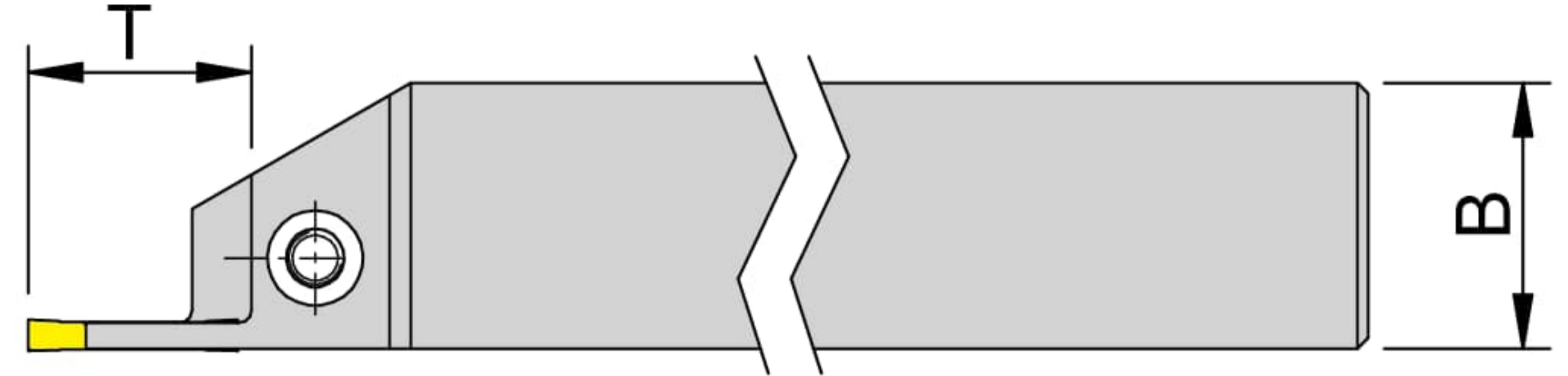
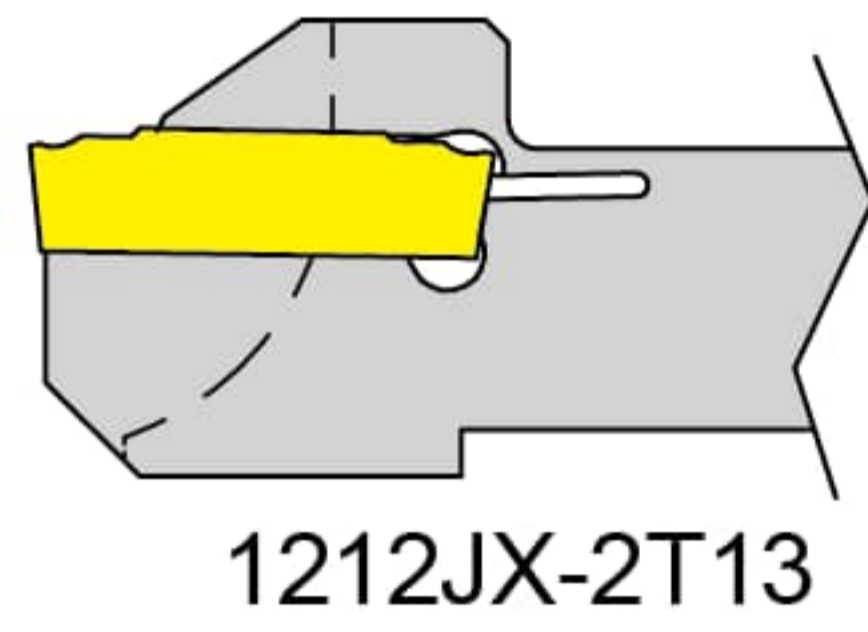
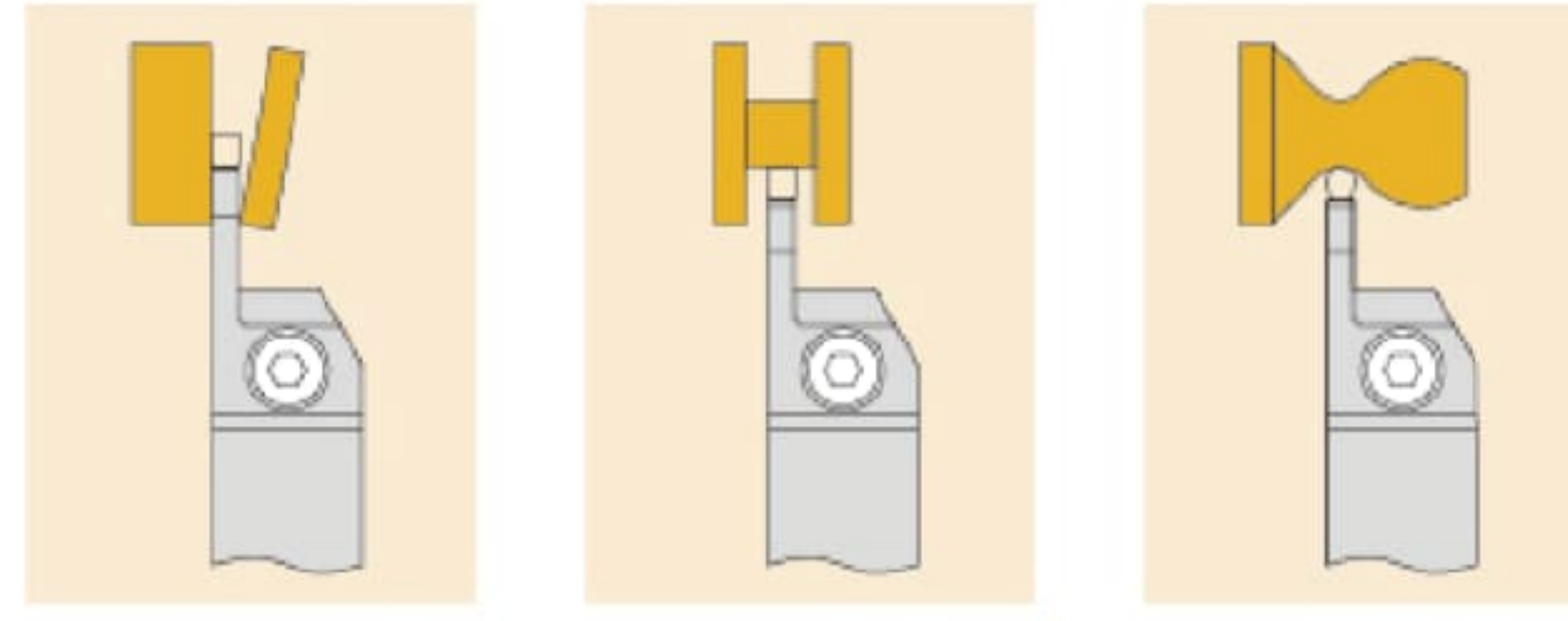

■ Right hand tool holder shown.(For Kyocera Insert)

Order number	Dimensions (mm)				Insert number	Screw	Wrench
	HxB	L	T	W			
KGDR/L1212JX-2T13	12	120	13	2.0	GDM 2420N GDMS 2220N	BFTX 04515	TRX 15
KGDR/L1616JX-2T17	16	120	17	2.0			
KGDR/L2020K-2T17	20	125	17	2.0	GDG 2520N GDM 2020N GDMS 2020N	BX 0520	LH-040
KGDR/L2525M-2T17	25	150	17	2.0			
KGDR/L2020K-3T20	20	125	20	3.0	GDM 3020N GDMS 3020N GDG 2520N GDM 3020N 150R GDMS 3020N	BX 0520	LH-040
KGDR/L2525M-3T20	25	150	20	3.0			

A32CR/L NEW

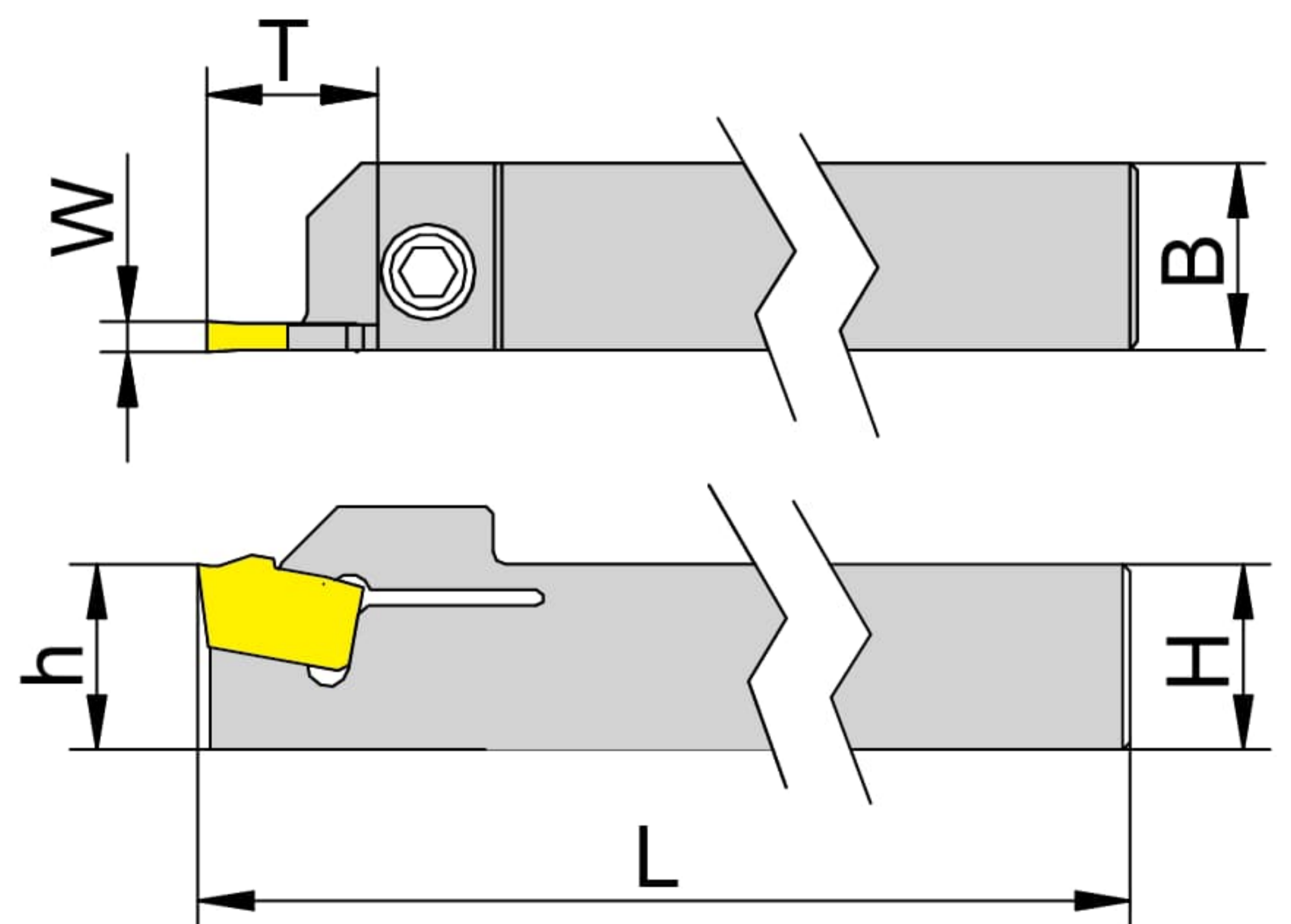
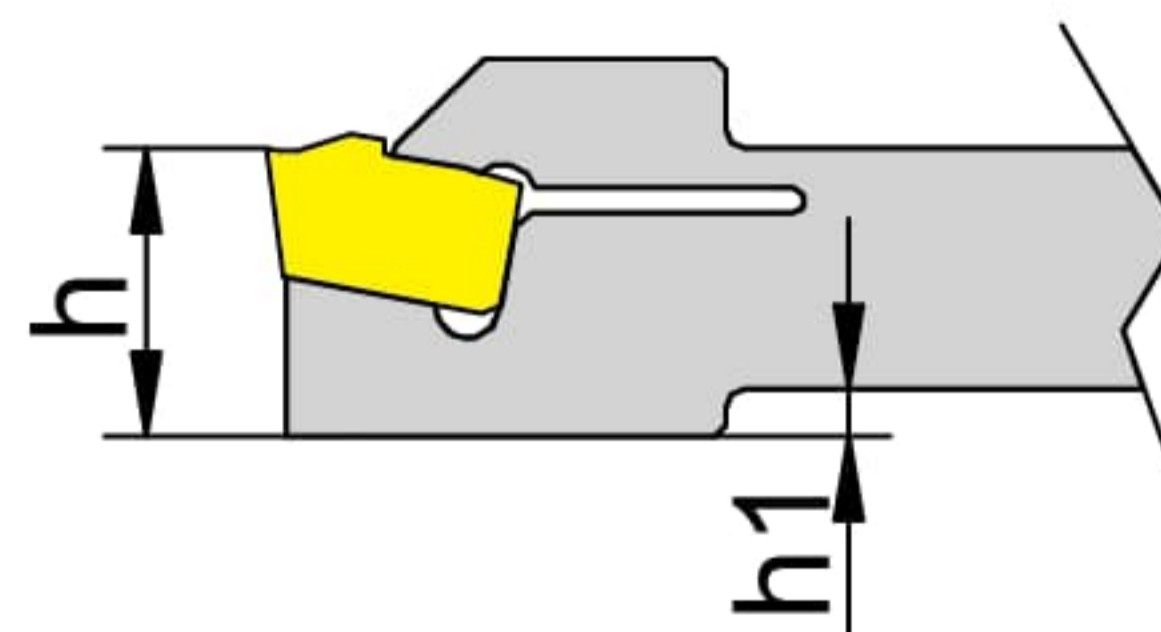
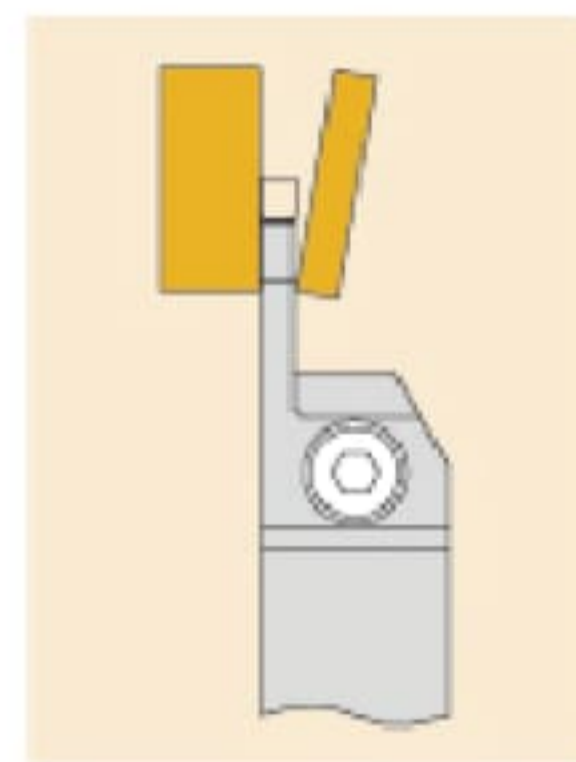
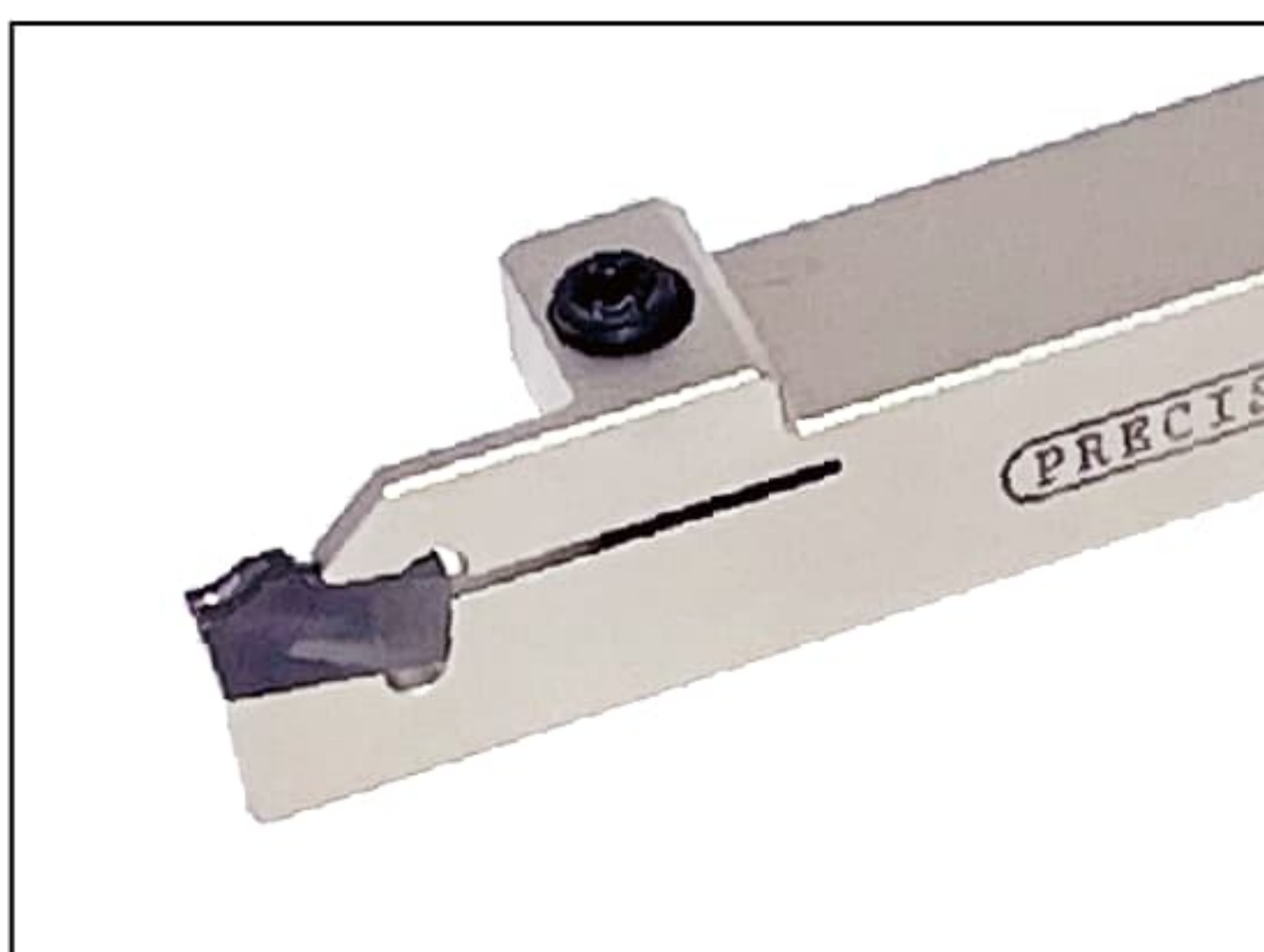

■ Right hand tool holder shown.(For Kennametal Insert)

Order number	Dimensions (mm)						Insert number	Screw	Wrench
	HxB	L	T	W	h	h1			
A3SCR/L 1010K 0210	10	125	10	2.0	10	2.0	A202.....	BFTX 0410	TRX15
A3SCR/L 1212K 0110	12	125	10	1.0	12		A201(1B)....		
A3SCR/L 1212K 0210	12	125	10	2.0	12		A202.....		
A3SCR/L 1212K 0216	12	125	16	2.0	12		A202.....		