

DGHR/L

外徑霸王刀架

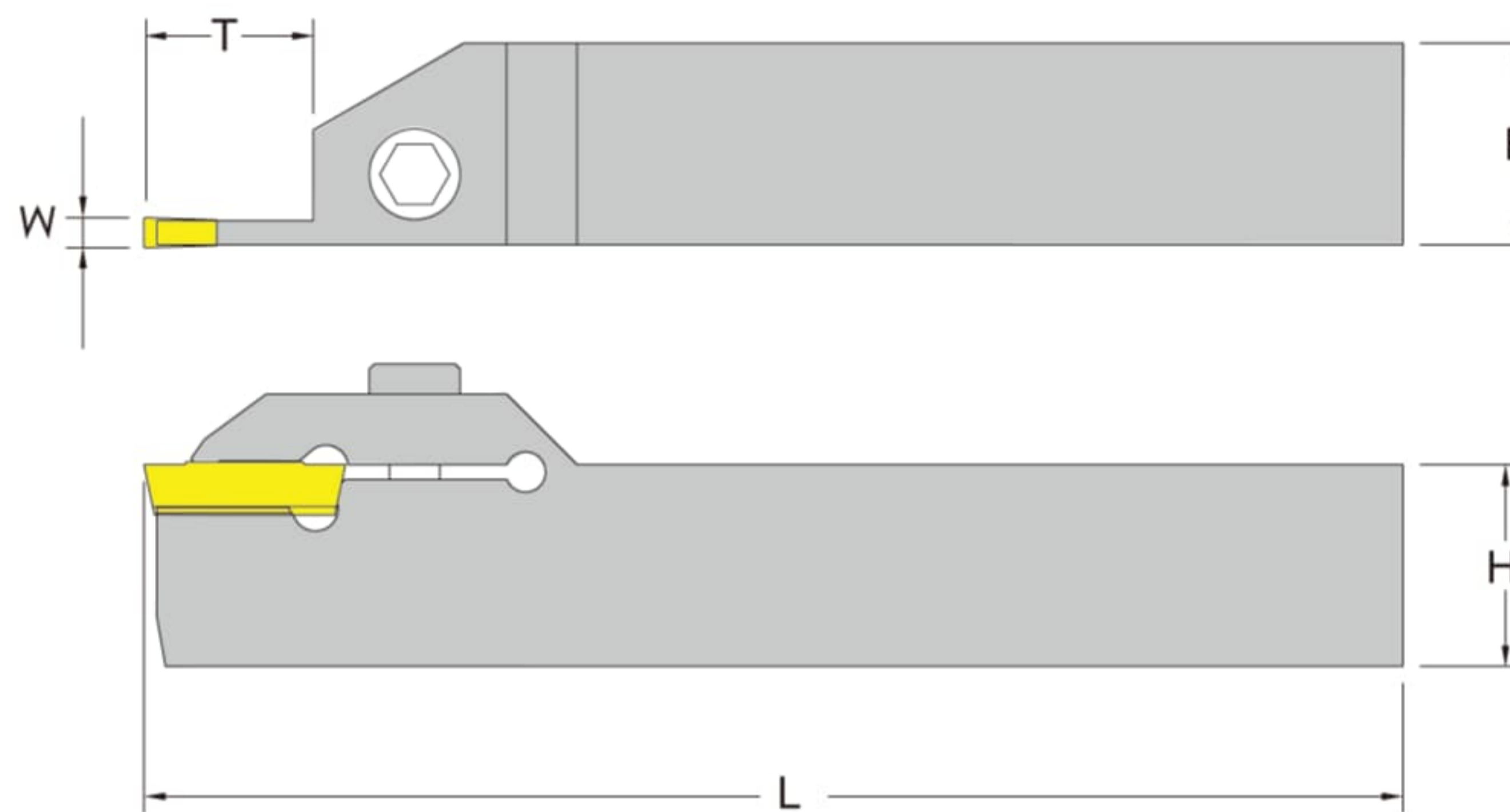
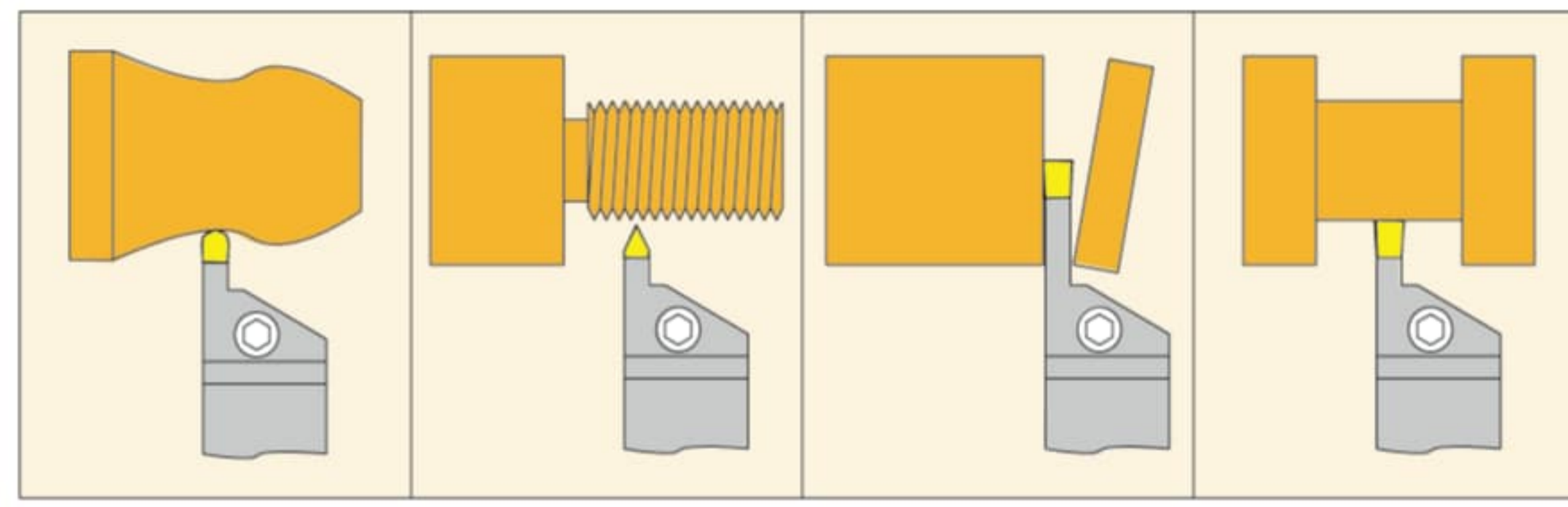
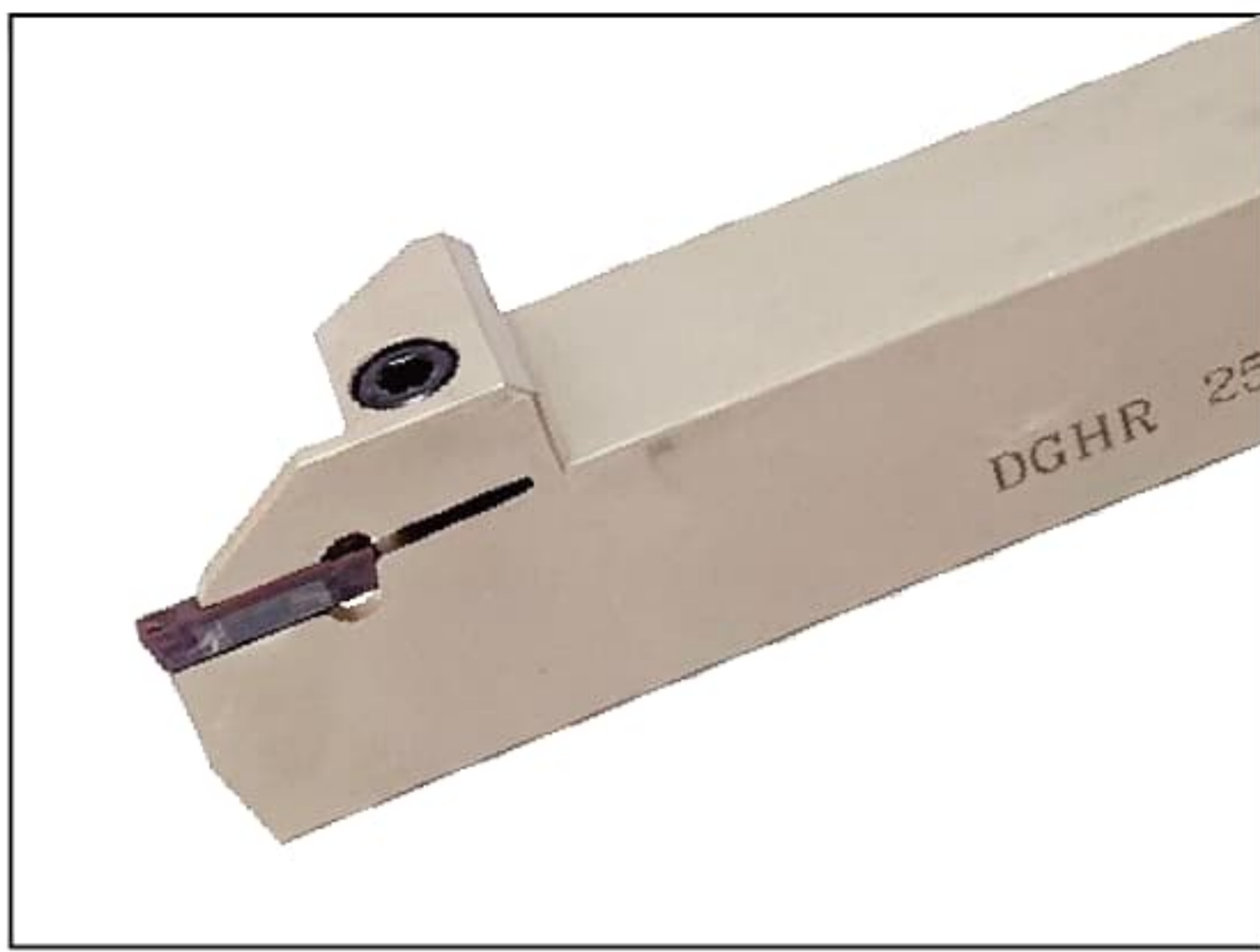

C

■ Right hand tool holder shown.(For Mitsubishi Insert)

| Order number | Insert number | Dimensions (mm) | | | | | Screw | Wrench |
|-----------------|---------------|-----------------|----|-----|----|-----|--------|--------|
| | | H | B | L | T | W | | |
| DGHR/L 2020K-3S | DGM30CT | 20 | 20 | 125 | 11 | 3.0 | BX0520 | LH-040 |
| 2525M-3S | | 25 | 25 | 150 | | | | |
| 2020K-4S | DGM40CT | 20 | 20 | 125 | | 4.0 | | |
| 2525M-4S | | 25 | 25 | 150 | | | | |
| 2525M-5S | DGM50CT | 25 | 25 | 150 | 16 | 5.0 | | |

| Order number | Insert number | Dimensions (mm) | | | | | Screw | Wrench |
|--------------------|---------------|-----------------|----|-----|----|-----|--------|--------|
| | | H | B | L | T | W | | |
| DGHR/L 2020K-2T20E | DGM20CE | 20 | 20 | 125 | 20 | 2.0 | BX0520 | LH-040 |
| 2525M-2T20E | | 25 | 25 | 150 | | | | |
| 2020K-3T20E | DGM30CE | 20 | 20 | 125 | | 3.0 | | |
| 2525M-3T20E | | 25 | 25 | 150 | | | | |
| 2020K-3T20 | DGM30CT | 20 | 20 | 125 | | 3.0 | | |
| 2525M-3T20 | | 25 | 25 | 150 | | | | |
| 2020K-4T20 | DGM40CT | 20 | 20 | 125 | | 4.0 | | |
| 2525M-4T20 | | 25 | 25 | 150 | | | | |
| 2525M-5T25 | DGM50CT | 25 | 25 | 150 | 25 | 5.0 | | |

KGMR/L 外徑霸王刀架

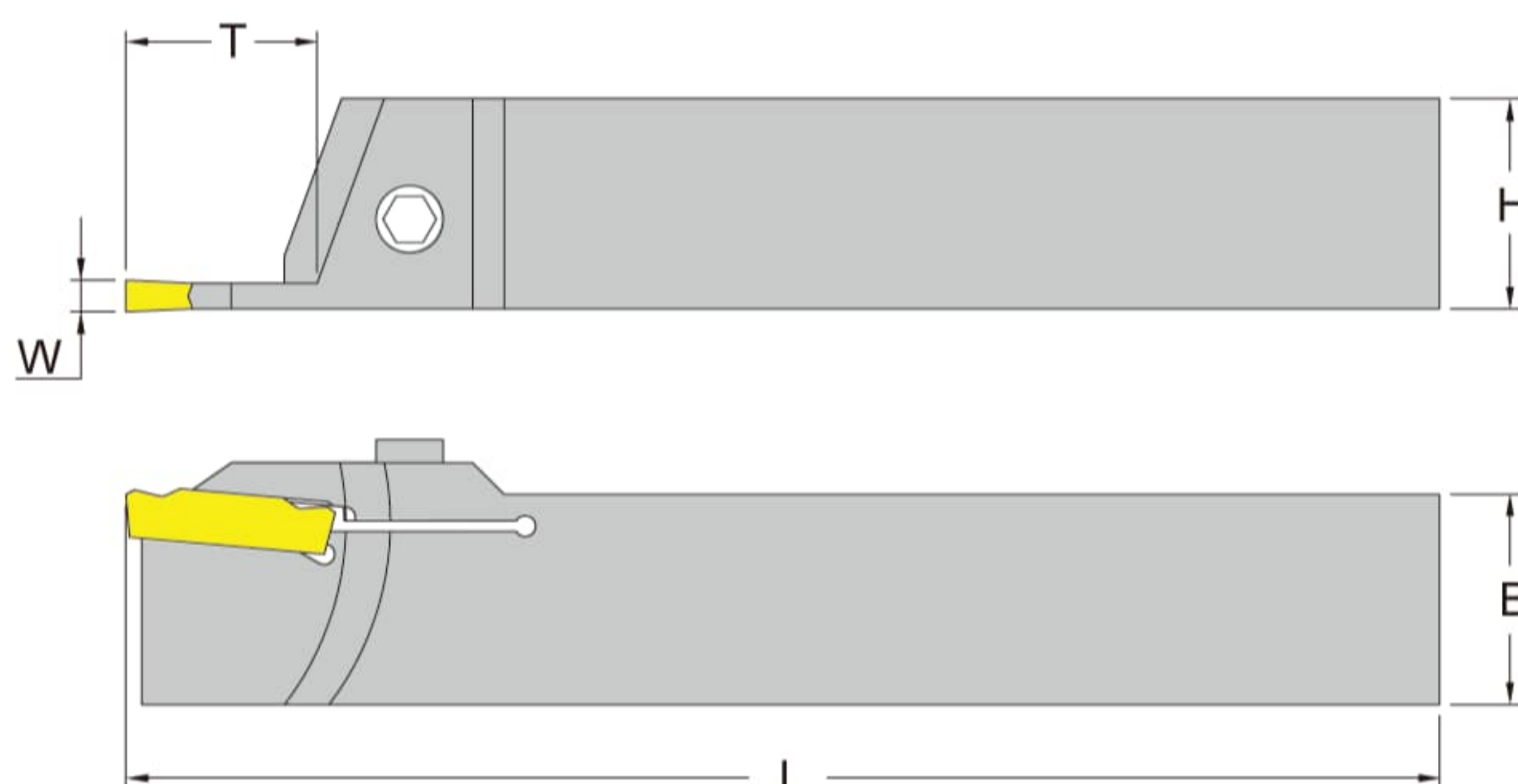
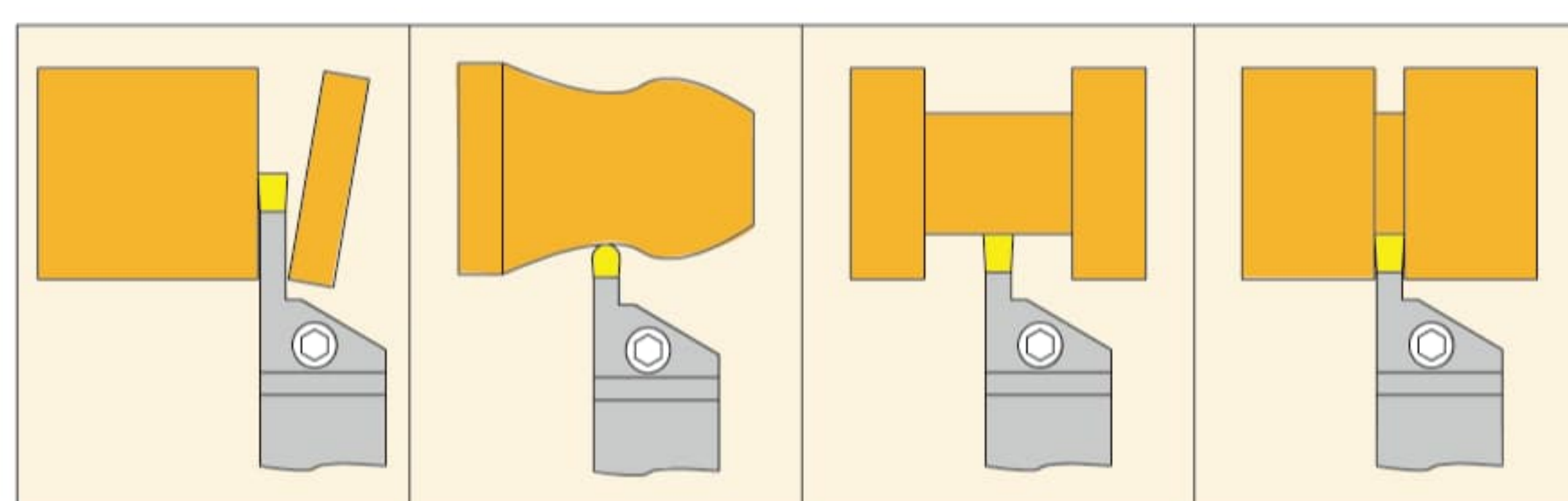

■ Right hand tool holder shown.(For Kyocera Insert)

| Order number | Insert number | Dimensions (mm) | | | | | Screw | Wrench |
|----------------|---------------|-----------------|----|----|-----|----|--------|--------|
| | | W | H | B | L | T | | |
| KGMR/L 2020K-3 | GMM3020- | 3.0 | 20 | 20 | 125 | 9 | BX0520 | LH-040 |
| 2020K-4 | GMM4020- | 4.0 | | | | 10 | | |
| 2525M-3 | GMM3020- | 3.0 | 25 | 25 | 150 | 9 | | |
| 2525M-4 | GMM4020- | 4.0 | | | | 10 | | |

| Order number | Insert number | Dimensions (mm) | | | | | Screw | Wrench |
|-------------------|----------------------|-----------------|----|----|-----|----|--------|--------|
| | | W | H | B | L | T | | |
| KGMR/L 1010H-2T14 | GMM2020- GMM2520- | 2.2 | 10 | 10 | 100 | 14 | BX0412 | LH-030 |
| 1212K-2T14 | | | 12 | 12 | 125 | 14 | | |
| 1616K-2T17 | | | 16 | 16 | | 17 | | |
| 1616K-3T20 | GMM3020- | 3.0 | 16 | 16 | 125 | 20 | BX0516 | LH-040 |
| 2020K-2T17 | GMM2020- | 2.2 | 20 | 20 | | 17 | BX0520 | |
| 2020K-3T20 | GMM3020- | 3.0 | | | 20 | | | |
| 2020K-4T20 | GMM4020- | 4.0 | | | 20 | | | |
| 2525M-2T17 | GMM2020- | 2.2 | | | 25 | 25 | | 150 |
| 2525M-3T20 | GMM3020- | 3.0 | 20 | | | | | |
| 2525M-4T20 | GMM4020- | 4.0 | 20 | | | | | |
| 2525M-4T25 | | | | 25 | | | | |
| 2525M-5T25 | GMM5020- | 5.0 | 25 | | | | | |

C

GHGR/GHDR 外徑霸王刀架

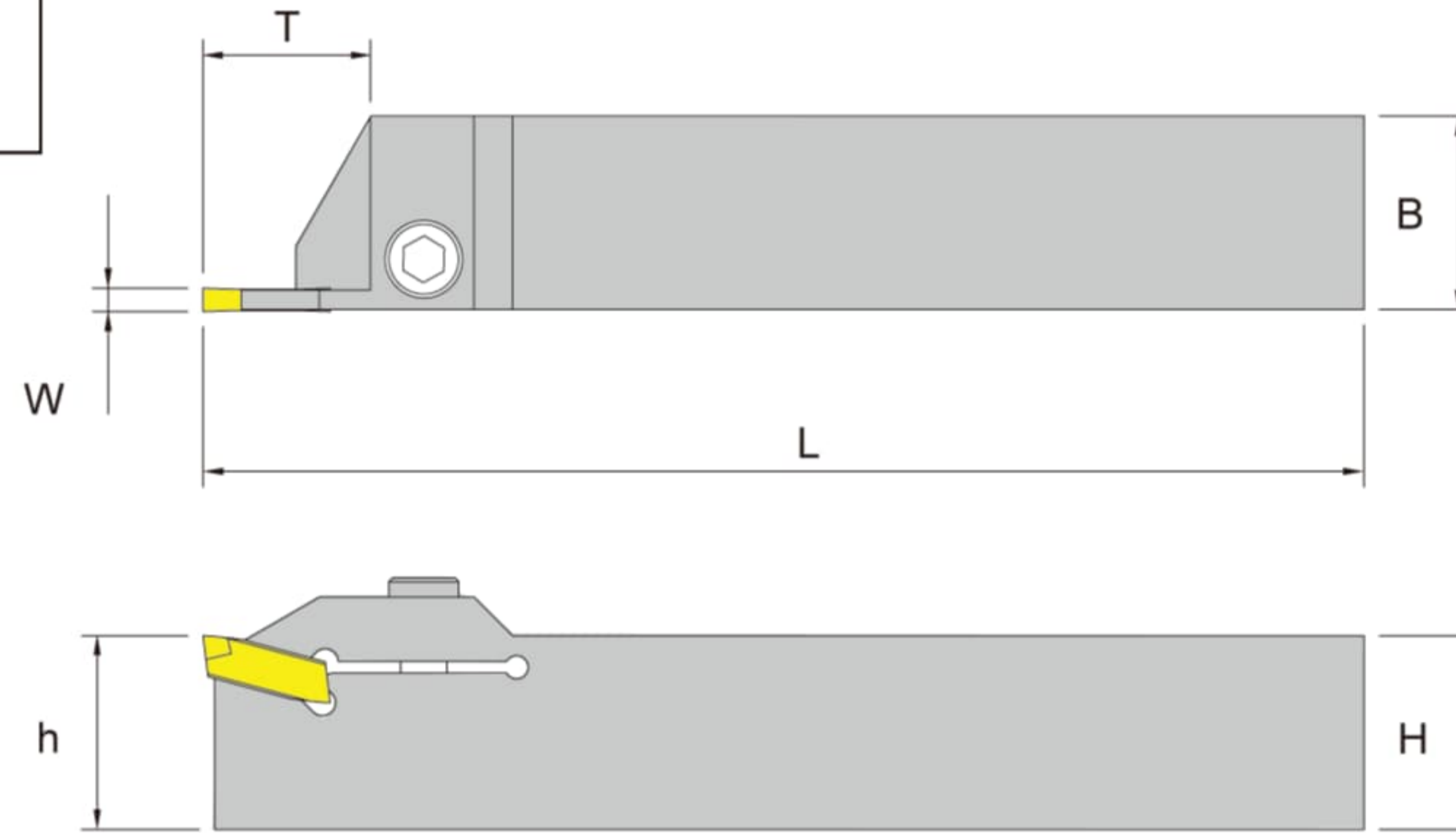
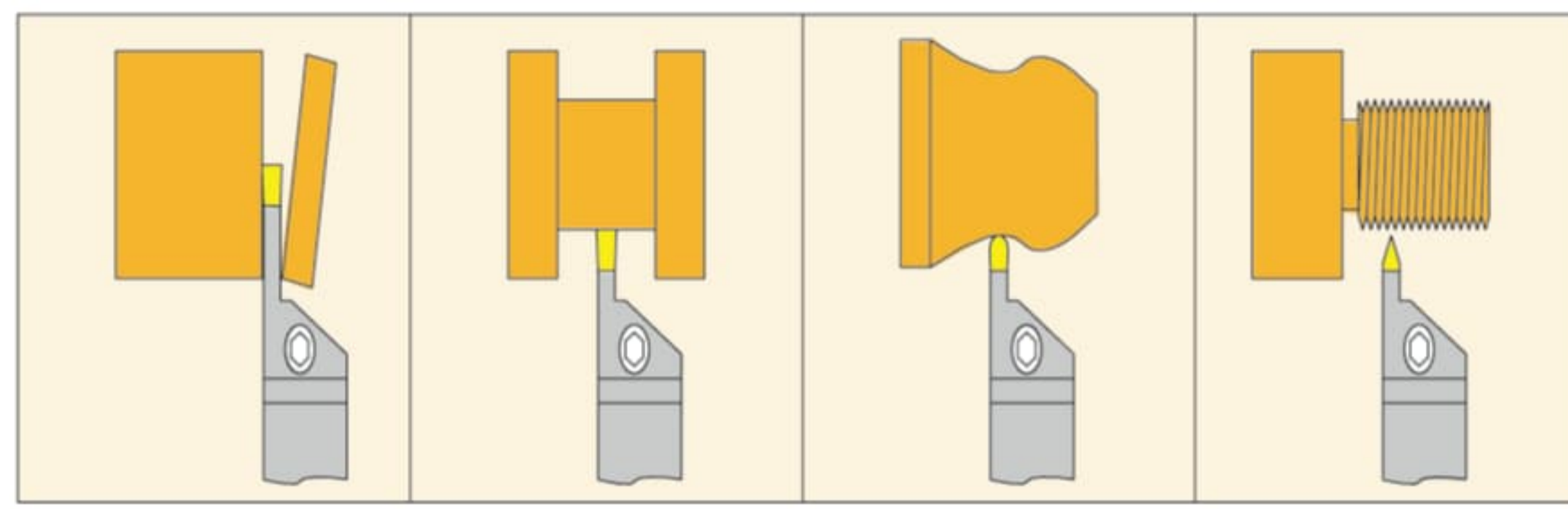

C

■ Right hand tool holder shown.(For Iscar Insert)

| Order number | Insert number | Dimensions (mm) | | | | | Screw | Wrench |
|--------------|---------------|-----------------|----|----|-----|----|--------|--------|
| | | W | H | B | L | T | | |
| GHGR/L 16-3 | GIP-3 | 3 | 16 | 16 | 125 | 20 | BX0620 | LH-050 |
| 20-2 | GIP-2 | 2 | 20 | 20 | | 17 | | |
| 20-3 | GIP-3 | 3 | | | | 20 | | |
| 20-4 | GIP-4 | 4 | | | | 20 | | |
| 25-2 | GIP-2 | 2 | 25 | 25 | 150 | 17 | | |
| 25-3 | GIP-3 | 3 | | | | 20 | | |
| 25-4 | GIP-4 | 4 | | | | 20 | | |
| 25-5 | GIP-5 | 5 | | | | 25 | | |

| Order number | Insert number | Dimensions (mm) | | | | | Screw | Wrench | | | |
|--------------|---------------|-----------------|----|----|-----|----|--------|--------|----|----|-----|
| | | W | H | B | L | T | | | | | |
| GHDR/L 16-2 | GIP-2 | 2 | 16 | 16 | 125 | 9 | BX0620 | LH-050 | | | |
| 16-3 | GIP-3 | 3 | | | | | | | | | |
| 20-2 | GIP-2 | 2 | | | | | | | 20 | 20 | 125 |
| 20-3 | GIP-3 | 3 | | | | | | | | | |
| 25-2 | GIP-2 | 2 | 25 | 25 | 150 | 9 | | | | | |
| 25-3 | GIP-3 | 3 | | | | 10 | | | | | |
| 25-4 | GIP-4 | 4 | | | | | | | | | |
| 25-5 | GIP-5 | 5 | | | | | | | 12 | | |

TTER/L 外徑霸王刀架

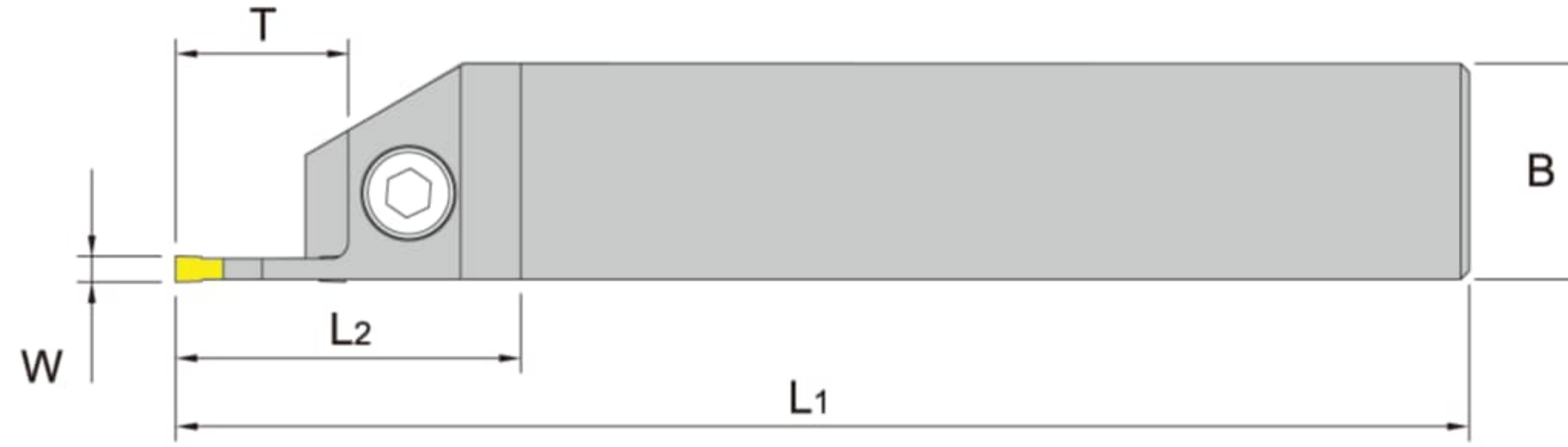
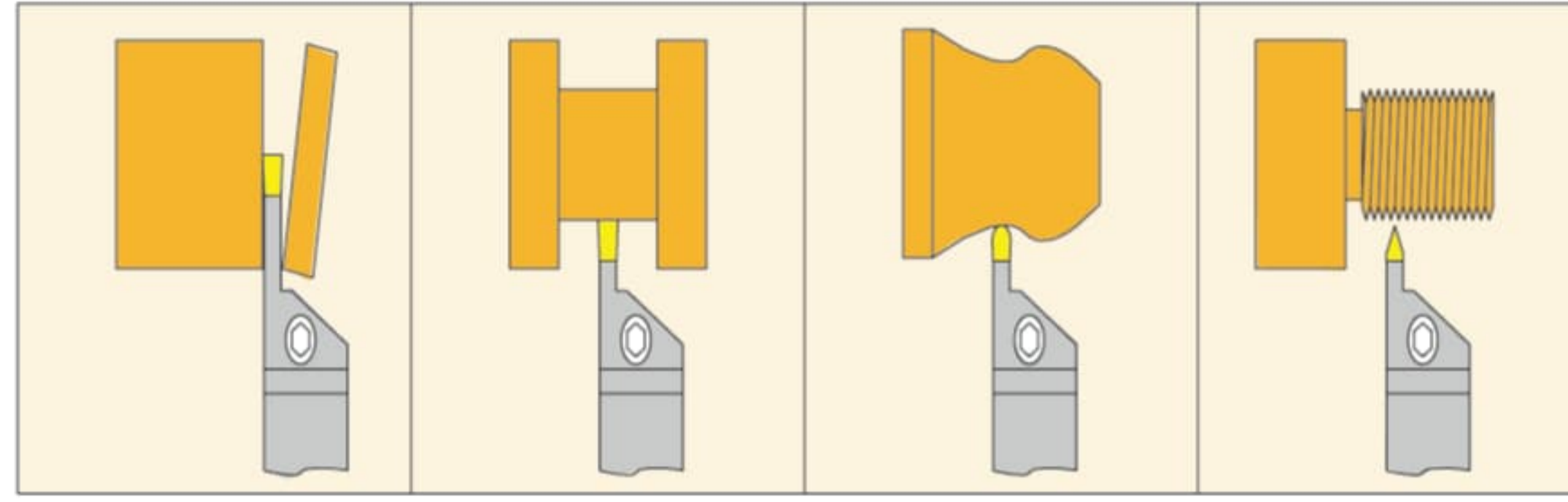
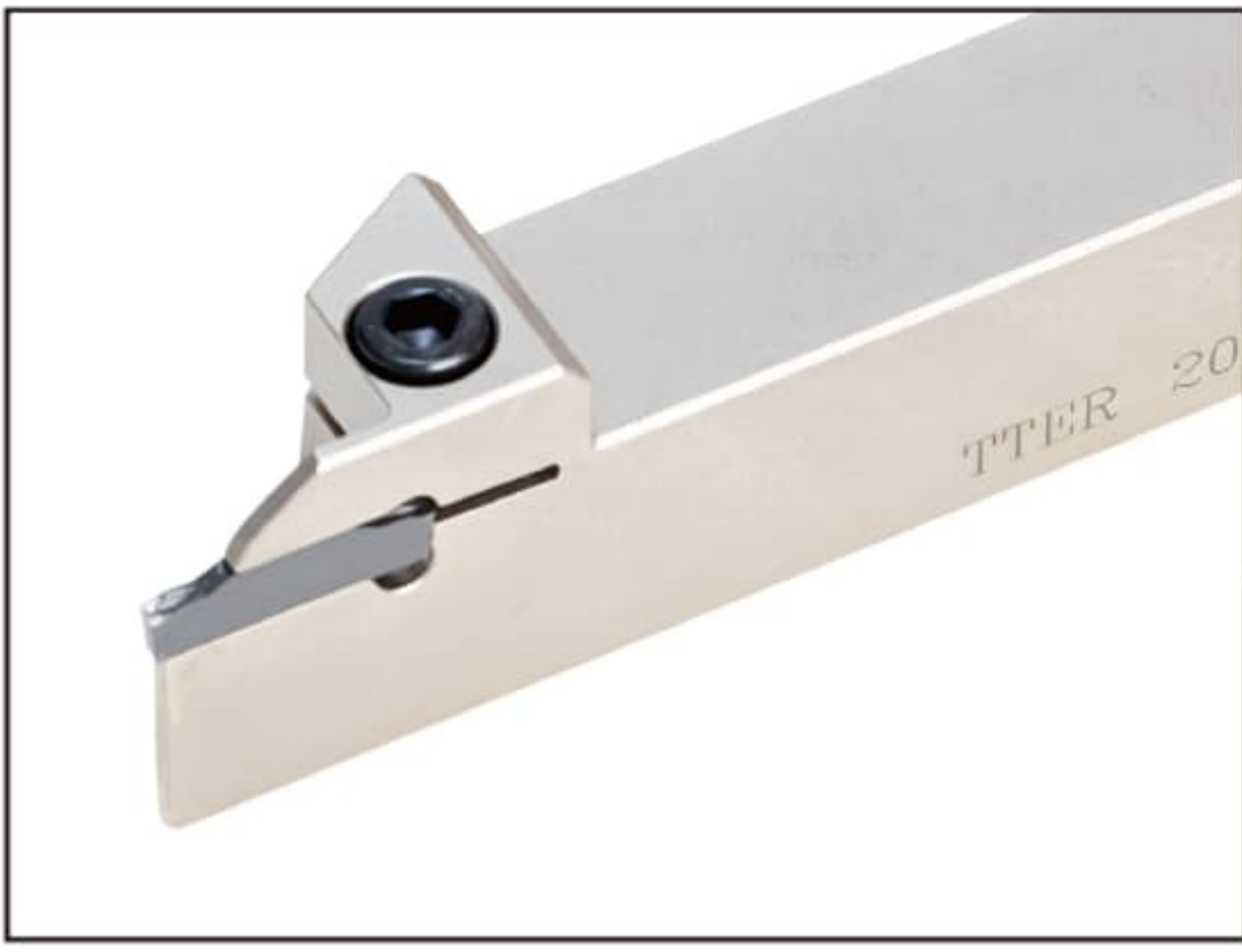

■ Right hand tool holder shown.(For Taegutec Insert)

| Order number | Insert number | Dimensions (mm) | | | | | | Screw | Wrench | | |
|------------------------------|--|-----------------|----|----|-----|----|-----|--------|--------|----|----|
| | | W | H | B | L1 | L2 | T | | | | |
| TTER/L 1616K-2T09 | TDJ/C TSJ/C TDT TDG TDXU4E | 2 | 16 | 16 | 125 | 40 | 9 | BX0620 | LH-050 | | |
| 1616K-3T09 | | 3 | | | | | | | | | |
| 2020K-2T09 | | 2 | 20 | 20 | | | 10 | | | | |
| 2020K-3T09 | | 3 | | | | | | | | | |
| 2020K-4T10 | | 4 | | | | | | | | | |
| 2525M-2T09 | | 2 | 25 | 25 | | | 150 | | | 40 | 9 |
| 2525M-3T09 | | 3 | | | | | | | | | |
| 2525M-4T10 | | 4 | | | | | | | | | 10 |
| 2525M-5T12 | | 5 | | | | | | | | | |

| Order number | Insert number | Dimensions (mm) | | | | | | Screw | Wrench | | |
|--------------------|--|-----------------|----|----|-----|----|-----|--------|--------|----|----|
| | | W | H | B | L1 | L2 | T | | | | |
| TTER/L 1616K- 2T17 | TDJ/C TSJ/C TDT TDG TDXU4E | 2 | 16 | 16 | 125 | 40 | 17 | BX0620 | LH-050 | | |
| 1616K-3T20 | | 3 | | | | | 20 | | | | |
| 2020K-2T17 | | 2 | 20 | 20 | | | 20 | | | | |
| 2020K-3T20 | | 3 | | | | | | | | | |
| 2020K-4T20 | | 4 | | | | | | | | | |
| 2525M-2T17 | | 2 | 25 | 25 | | | 150 | | | 40 | 17 |
| 2525M-3T20 | | 3 | | | | | | | | | |
| 2525M-4T20 | | 4 | | | | | | | | | 20 |
| 2525M-5T25 | | 5 | | | | | | | | | |

C